

# SPECIFICATIONS

## BASE CABINETS

( See “Cabinet Construction Specifications” and “Pricing Procedures” for options.)

### Base Cabinet Nomenclature

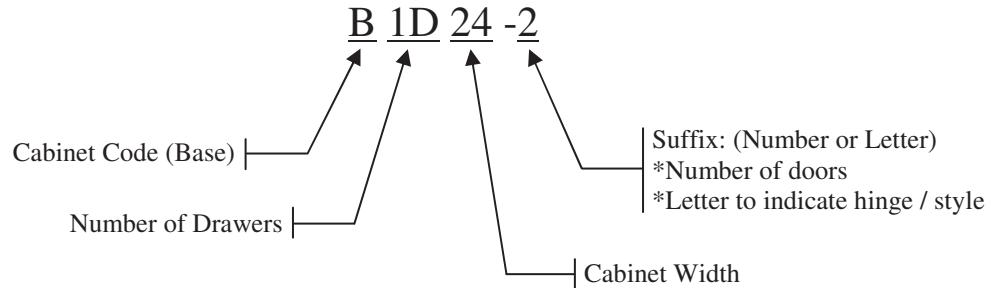

STANDARD BASE FRONT FRAME HEIGHT: 30"  
 STANDARD OVERALL CABINET HEIGHT: 34 1/2" \*\*  
 STANDARD OVERALL CABINET DEPTH: 13" & 24" \*\*  
 STANDARD TOE KICK HEIGHT: 4 1/2"; DEPTH: 3 1/2"

**\*\*Base cabinets will have a standard height of 34 1/2" and standard depth of 24" unless specifically noted in the cabinet's description.**

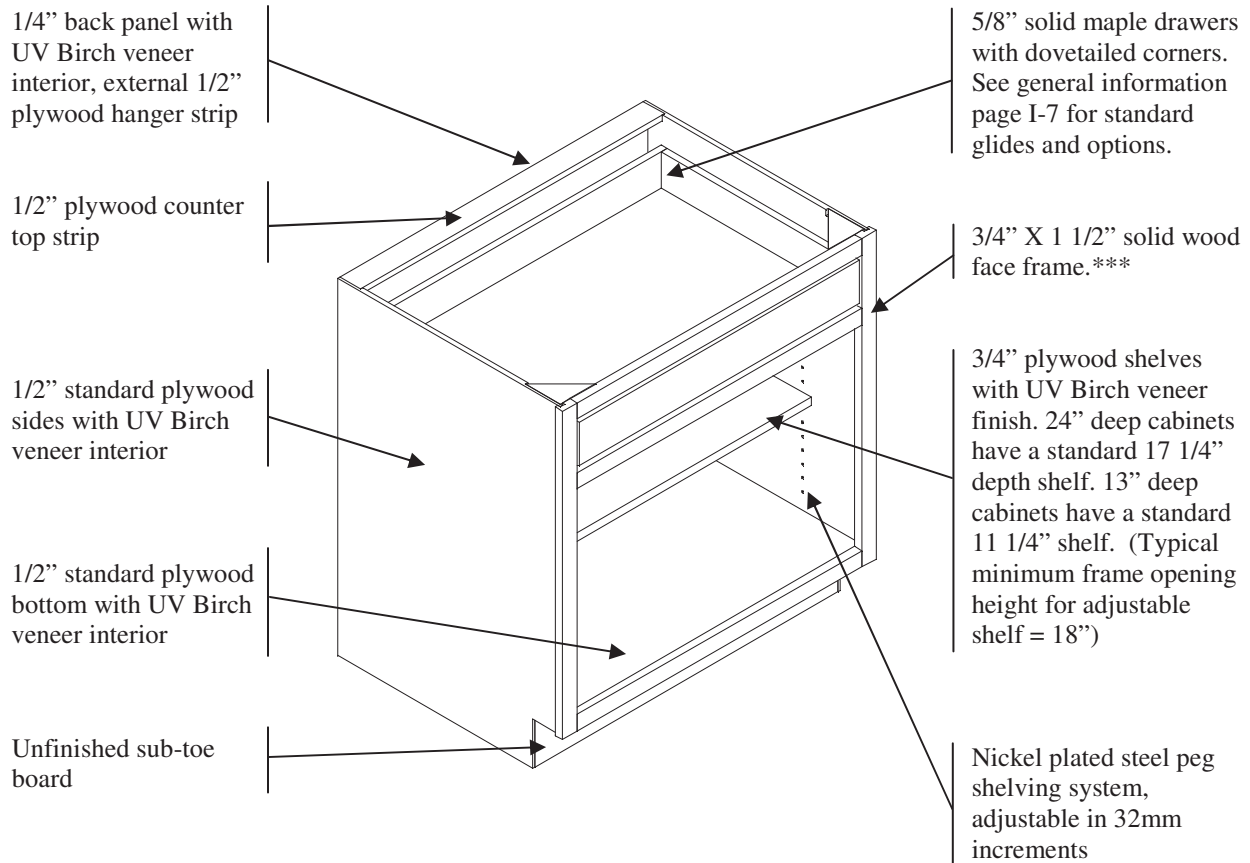

\*\*\*Cabinets less than 9" wide will have reduced face frame stile widths.



# Base Contents

**Base cabinets will have a standard height of 34 1/2” and standard depth of 24” unless specifically noted. See the page with the cabinet details for additional information.**

<b>ANGLED CABINETS</b>		<b>KEYPAD DRAWERS.....</b>	51
135° ANGLED CORNER CABINET.....	39	<b>MULTI-FOOD STORAGE.....</b>	45
ANGLED FRONT CABINET.....	40	<b>PENINSULA CABINET (double entry).....</b>	35-37
DOUBLE ANGLE CABINET.....	42	<b>PENINSULA STARTER CABINET.....</b>	35
SINGLE ANGLE CABINET.....	42	<b>PIE CUT CORNER CABINETS</b>	
THREE ANGLE CABINET.....	43	WITH ADJUSTABLE SHELF.....	23
<b>APPLIANCE CABINETS</b>		WITH DRAWERS.....	21
APPLIANCE PLATFORM DRAWER.....	29	WITH REVOLVING DOOR.....	23
APPLIANCE TOE PLATE.....	29	WITH ULTRA SUSAN REVOLVING SHELF.....	23
BASE COOK TOP CABINETS.....	33-34	<b>PLANNING DESKS.....</b>	50
DOWN DRAFT CABINET.....	31	<b>RADIUS CABINET.....</b>	43
MICROWAVE CABINET.....	31	RADIUS END ENTRY CABINET.....	41
UNDER COUNTER OVEN CABINET.....	29	RADIUS PENINSULA CABINET.....	38
WARMING DRAWER.....	33	RADIUS SINK BASE.....	12
<b>BLIND CORNER CABINET.....</b>	9	<b>SINK BASES</b>	
PENINSULA BLIND (double entry).....	35	1 FALSE TOP DRAWER.....	10B
WITH PULLOUT / SWINGOUT.....	10	2 FALSE TOP DRAWERS.....	10B
WITH SWING OUT WOOD SHELF.....	10	ANGLED SINK FRONT.....	25
<b>CANNED GOODS STORAGE.....</b>	45	ANGLED SINK FRONT FLOOR.....	25
<b>DIAGONAL CORNER CABINETS</b>		DIAGONAL CORNER SINK BASE.....	27
WITH ADJUSTABLE SHELF.....	24	DIAGONAL SHALLOW CORNER SINK.....	26
ULTRA SUSAN REVOLVING SHELF.....	24	FARMER SINK.....	10B
SEE SINK BASES FOR DIAGONAL CORNER SINKS		FULL HEIGHT DOOR SINK.....	11
<b>DOOR / DRAWER CABINETS</b>		RADIUS SINK.....	12
1 TOP DRAWER.....	8	RECESSED CORNER SINK.....	27
1 TOP DRAWER W/ ROLLOUTS.....	15	WITH CLIP CORNER.....	14
2 TOP DRAWER.....	8	WITH POST NOTCH.....	13
2 TOP DRAWER W/ ROLLOUTS.....	16	<b>SHELF UNITS</b>	
3 TOP DRAWER/3 DOOR.....	8	END SHELVES.....	52
COMBINATION DOUBLE DRAWER.....	44	PENINSULA END SHELF.....	52
INVERTED BASE CABINET.....	9	<b>TRAY DIVIDER CABINET.....</b>	7
<b>DOUBLE ENTRY- SEE PENINSULA CABINETS</b>		<b>TRAY PULLOUT CABINET.....</b>	7
<b>DRAWER BANKS</b>		<b>WASTE CABINET.....</b>	17
APOTHECARY DRAWERS.....	47	<b>WICKER SPICE DRAWER CABINET.....</b>	47
2 EQUAL DRAWER.....	19	<b>WICKER VEGETABLE BASKET CABINETS.....</b>	46
2-SEED DRAWER CABINETS.....	19	<b>WINE RACK CABINETS.....</b>	48-48a
2 TOP DRAWERS, 4 DRAWER TOTAL.....	21		
3 DRAWER.....	20		
4 DRAWER.....	20		
<b>FULL HEIGHT DOOR CABINET.....</b>	6		
13” DEEP.....	4-5		
<b>IRONING BOARD CABINET.....</b>	44		
<b>ISLAND TABLE, FREE STANDING.....</b>	49		



# Base Contents

## BASE ACCESSORIES

150# FULL EXT. SIDE-MOUNT GLIDES.....	59
BLUMOTION GLIDES.....	59
BREAD BOX LID.....	59
CAN RACK.....	58
CUTLERY DIVIDER.....	59, 60B
CUTTING BOARD BEHIND DRAWER.....	58
CUTTING BOARD OVER DRAWER.....	58
DISHWASHER END PANEL.....	54
DOUBLE STACK CUTLERY DIVIDER.....	59
DRAWER DIVIDER.....	59
END SKIN, LOOSE.....	62
FLIPPER DOOR GLIDES.....	58
FURNITURE PLATFORMS.....	57
KNIFE BLOCK.....	60B
HAMPER BASKET ROLLOUT.....	62
HANGING FILE RAILS.....	59
ISLAND END PANELS.....	49
MIXER SHELF, LIFT UP.....	62
MYSTERY OIL.....	58
PARTITION.....	62
PLANNING DESK LEG.....	50
POT AND PAN CADDY.....	62
ROLLOUT SHELVES.....	60
SINK BASE DRIP TRAY.....	62A
SPICE RACK IN DRAWER.....	59
SPICE RACK ON DOOR.....	58
TILT OUT SOAP TRAYS.....	59
TOE FILLER (ARCHED).....	56
TOE FILLER (FURNITURE).....	56
TOE KICK DRAWER.....	61
TOE KICK STEP STOOL.....	61
TOWEL RACK, METAL.....	62
TRAY DIVIDER.....	62
VEGETABLE BIN.....	62
WASTE BASKET, DOUBLE.....	58
WASTE BASKET, SINGLE.....	58
WOOD REVOLVING SHELF.....	62A

## FILLERS

ANGLED FILLERS.....	55
ANGLED FILLERS WITH RETURN.....	55
3" AND 6" STRAIGHT.....	53
CORNER FILLERS.....	53
DISHWASHER END PANEL.....	54
FILLER WITH RETURN.....	54
FILLER WITH BOTH RETURNS.....	54
OVERLAY FILLER.....	53
SPICE FILLER PULLOUT, 3" AND 6" WIDE.....	54

## BASE MODIFICATIONS

90 DEGREE HINGE.....	69
ADD CENTER RAIL.....	62B
ADD CENTER STILE.....	62B
ADDITIONAL DRAWER.....	69
ANGLED SIDE ENTRY.....	67
ANGLED FRONT.....	67
ANGLED SIDE.....	67
APPLIED MOLDING CHARGE.....	62B
BACK TOE KICK.....	67
BEAD BOARD END.....	64
BLIND BASE CUSTOM FRONT.....	67
BLIND SOLID, FINISHED.....	9, 67
CLIPPED CORNER.....	68
COMBINED CABINET CHARGE.....	62B
DOOR STAY.....	69
DOUBLE ENTRY.....	67
DRAWER HEAD UPGRADE.....	69
DRY-SEED DRAWER FRONT.....	69
DUCT CUT-OUT.....	68
END ENTRY.....	67
EXTEND RAIL, UP OR DOWN.....	65
EXTEND SIDE BACK.....	65
EXTENDED STILE.....	65
FALSE DOOR ON END.....	64
FINISHED BACK 1/2".....	64
FINISHED END.....	64
FINISHED TOP.....	64
FLUSH FINISHED END.....	64
FLUSH FINISHED TOP.....	64
FLUSH TOE BASE.....	67
FLUTING.....	68
FRAME CHANGE.....	62B
FRONT ONLY.....	62B
FURNITURE END.....	63
GROOVED PANEL APPLIED.....	64
INCREASE CASE DIMENSION CHARGE.....	62B
INWARD EXTENDED STILE.....	65
LOOSE TOE KICK.....	67
MATCHING WOOD INTERIOR.....	62B
OMIT DOORS.....	62B
OMIT OPERATING DRAWER BOX.....	69
OMIT TOE KICK.....	67
RECESS POST CUTOUT.....	68
RECESSED SIDE.....	65
ROSETTE DESIGN.....	68
SCOOPED DRAWER SIDES.....	69
SIDE TOE KICK.....	67
SINK SIDE CUTOUT.....	68
UNIVERSAL ACCESS TOE KICK SPACE.....	68
U-SHAPE DRAWER BOX MODIFICATION.....	69
VALANCE TOP/BOTTOM RAIL.....	65
WAINSCOT END PANEL.....	64

**BASE CABINET FULL HEIGHT DOOR, 13" DEEP**

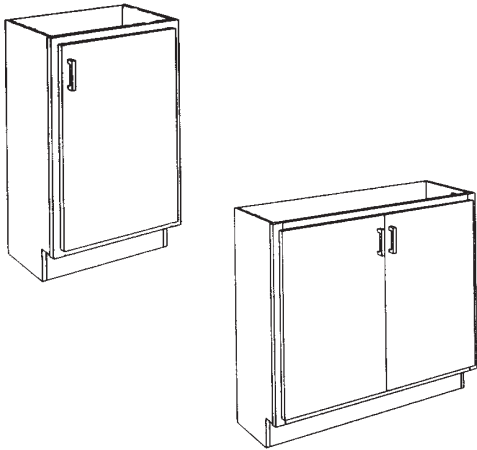

	PRODUCT CODE	LEVEL 1	LEVEL 2
One door	BFD913		
	BFD1213		
	BFD1513		
	BFD1813		
	BFD2113		
	BFD2413-1		

Two doors	BFD2413-2		
	BFD2713		
	BFD3013		
	BFD3313		
	BFD3613		
	BFD3913		
	BFD4213		
	BFD4513-2		
	BFD4813-2		

**BASE CABINETS WITH FULL HEIGHT DOORS**

- 13" deep, standard
- Two full depth, adjustable shelves.
- Specify hinge on single door cabinets.
- FOL cabinets modified to under 9" wide and SOL cabinets under 12" wide may have slab doors. See specific door styles for minimum sizes.
- Cabinets 39" wide or greater will have a fixed center stile as standard.
- Cabinets under 9" wide will have reduced width frame stiles.

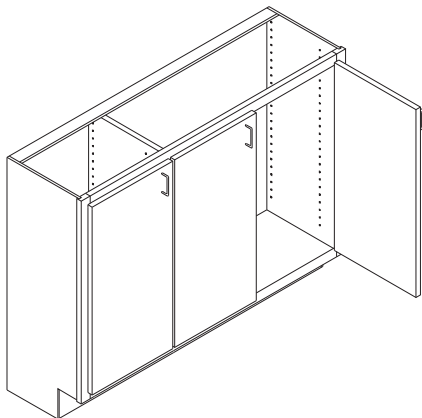

Three equal doors	BFD3913-3		
	BFD4213-3		
	BFD4513-3		
	BFD4813-3		
	BFD5113-3		
	BFD5413-3		

**BASE CABINETS WITH THREE FULL HEIGHT DOORS**

- 13" deep, standard
- Three equal door cabinets have a partition behind the middle, offset stile.
- Two full depth, adjustable shelves on each side of partition.
- Single door hinged to outer side unless specified.
- Specify side for single door on three door cabinets (left shown).

BASE CABINET FULL HEIGHT DOOR (13" Deep, 40 1/2 High)

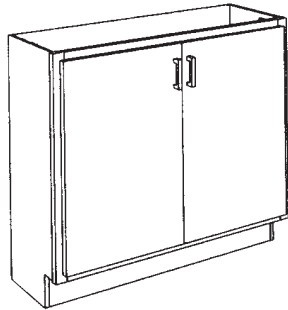
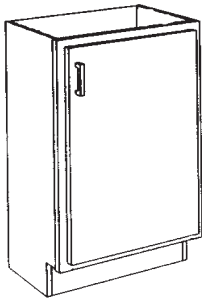

	PRODUCT CODE	LEVEL 1	LEVEL 2
One door	BFD940.513		
	BFD1240.513		
	BFD1540.513		
	BFD1840.513		
	BFD2140.513		
	BFD2440.513		
Two doors	BFD2440.513-2		
	BFD2740.513		
	BFD3040.513		
	BFD3340.513		
	BFD3640.513		
	BFD3940.513		
	BFD4240.513		
	BFD4540.513-2		
BFD4840.513-2			

**BASE CABINETS WITH FULL HEIGHT DOORS**

- 13" deep, 40 1/2" high standard
- Three full depth adjustable shelves.
- Specify hinge on single door cabinets.
- FOL cabinets modified to under 9" wide and SOL cabinets under 12" wide may have slab doors. See specific door styles for minimum sizes.
- Cabinets 39" wide or greater will have a fixed center stile as standard.
- Cabinets under 9" wide will have reduced width frame stiles.

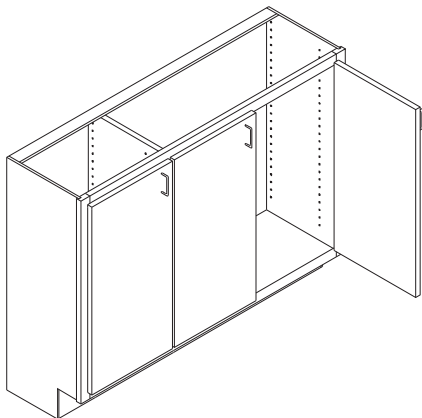

Three equal doors	BFD3940.513-3		
	BFD4240.513-3		
	BFD4540.513-3		
	BFD4840.513-3		
	BFD5140.513-3		
	BFD5440.513-3		

**BASE CABINETS WITH THREE FULL HEIGHT DOORS**

- 13" deep, 40 1/2" high standard
- Three equal door cabinets have a partition behind the middle, offset stile.
- Three full depth adjustable shelves on each side of partition.
- Single door hinged to outer side unless specified.
- Specify side for single door on 3 door cabinets (left shown).

**BASE CABINET FULL HEIGHT DOOR**

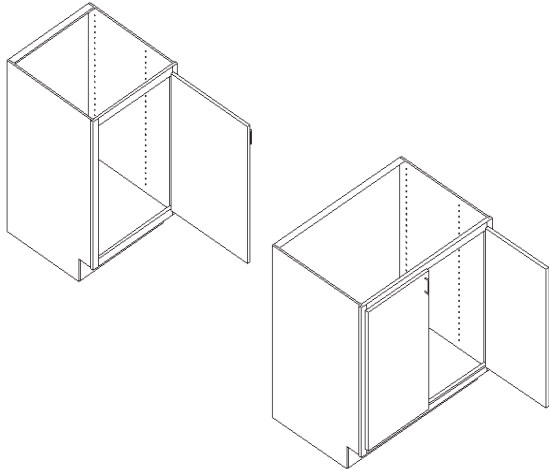

**BASE CABINETS WITH FULL HEIGHT DOORS**

- 24” deep
- Two 3/4 depth adjustable shelves.
- Specify hinge for single door cabinet.
- FOL cabinets modified to under 9” wide and SOL cabinets under 12” wide may have slab door. See specific door styles for minimum sizes.
- Cabinets 39” wide or greater will have a fixed center stile as standard.
- Cabinets under 9” wide will have reduced width frame stiles.

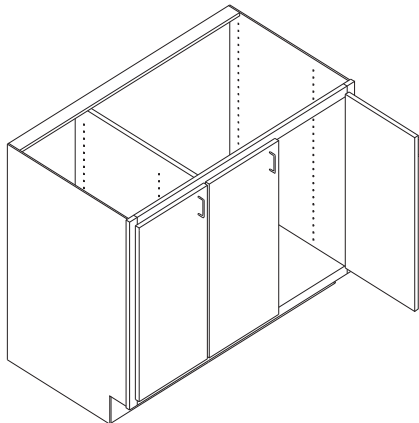

	PRODUCT CODE	LEVEL 1	LEVEL 2
One door	BFD624		
	BFD924		
	BFD1224		
	BFD1524		
	BFD1824		
	BFD2124		
	BFD2424-1		
Two doors	BFD2424-2		
	BFD2724		
	BFD3024		
	BFD3324		
	BFD3624		
	BFD3924		
	BFD4224		
Three equal doors	BFD4524-2		
	BFD4824-2		
	BFD3924-3		
	BFD4224-3		
	BFD4524-3		
	BFD4824-3		

**BASE CABINETS WITH THREE FULL HEIGHT DOORS**

- 24” deep
- Three equal door cabinets have a partition behind the middle, offset stile.
- Two 3/4 depth adjustable shelves on each side of partition.
- Single door hinged to outer side unless specified.
- Specify side for single door on 3 door cabinets (left shown).

**BASE WITH TRAY STORAGE**

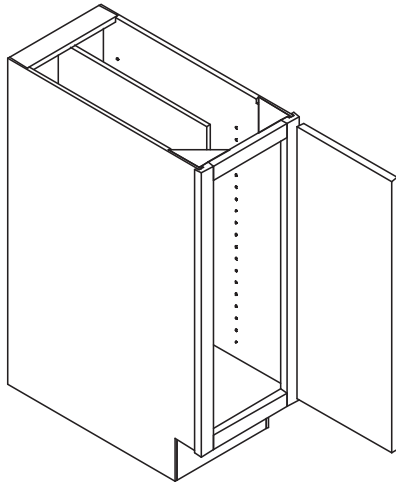

PRODUCT CODE	LEVEL 1	LEVEL 2
BFDTD6		
BFDTD9		
BFDTD12		
BFDTD15		

**BASE FULL HEIGHT DOOR WITH TRAY DIVIDER**

- 24" deep
- Cabinet with one centered, fixed 1/2" tray divider.
- Specify hinge side, L or R.
- No adjustable shelves.
- Cabinets under 9" wide will have reduced width frame stiles.
- FOL-C cabinets under 9" wide and SOL/Inset cabinets under 12" wide may have slab doors. See specific door styles for minimum sizes.



BTPC9
BTPC12
BTPC15

**BASE TRAY PULLOUT CABINET**

- 24" deep
- Pullout tray storage rack mounted to full height door.
- 100# full-extension, Blumotion undermount glides.
- Minimum width of 7 3/4".
- Cabinets under 9" wide will have reduced width frame stiles.
- FOL cabinets modified to under 9" wide and SOL cabinets under 12" wide may have slab door. See specific door styles for minimum sizes.

**BASE DRAWER / DOOR CABINETS**

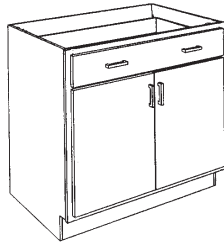
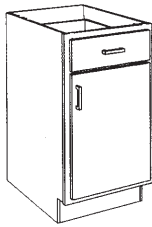

**BASE DRAWER(S) / DOOR(S) CABINET**

- One 3/4 depth adjustable shelf.
- Specify hinge side on single door cabinets.
- Cabinets 39" wide or greater will have a fixed center stile as standard.
- FOL cabinets modified to under 9" wide and SOL cabinets under 12" wide may have slab doors. See specific door styles for minimum sizes.
- Cabinets under 9" wide will have reduced width frame stiles.

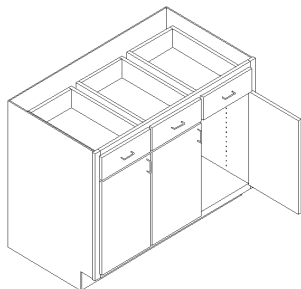
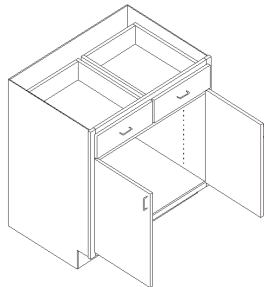

**BASE CABINETS WITH THREE DRAWERS / THREE DOORS**

- Three door base cabinets have a partition behind the middle, offset stile.
- One 3/4 depth adjustable shelf on each side of partition.
- Single door hinged to outer side unless specified.
- Specify side for single door opening on 3 door cabinets. (left shown)

	PRODUCT CODE	LEVEL 1	LEVEL 2
One drawer, one door	B9		
	B12		
	B15		
	B18		
	B21		
	B1D24-1		
One drawer, two doors	B1D24-2		
	B1D27		
	B1D30		
	B1D33		
	B1D36		
	B1D39		
	B1D42		
Two drawers, two doors	B27		
	B30		
	B33		
	B36		
	B39		
	B42		
	B45-2		
	B48-2		
Three equal drawers, three equal doors	B39-3		
	B42-3		
	B45-3		
	B48-3		
	B51-3		
	B54-3		



**INVERTED BASE 1 DRAWER / 2 DOOR**

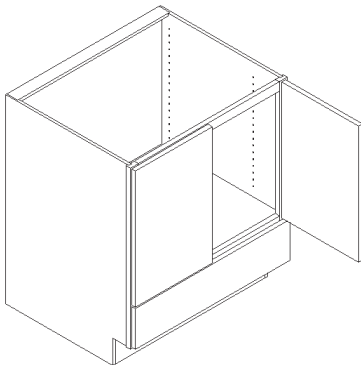

- 4" high drawer box at the bottom of the cabinet with 2 doors above.
- Fixed floor between door area and drawer box.
- One 3/4 depth adjustable shelf.

PRODUCT CODE	LEVEL 1	LEVEL 2
BI1D24-2		
BI1D27		
BI1D30		
BI1D33		
BI1D36		
BI1D39		
BI1D42		

**BASE BLIND CORNER CABINET**

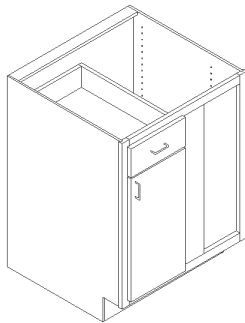

For a custom sized front in a Blind cabinet, see Blind Base Custom Front in Base Modifications

PRODUCT CODE	LEVEL 1	LEVEL 2
BBC36		
BBC39		
BBC42		
BBC45		
BBC48		
Base Finished Blind Solid		
MBFBS		

BLIND CORNER CABINET	DOOR OPENING	PULL LIMIT
BBC36	7 1/2"	39"
BBC39	10 1/2"	42"
BBC42	13 1/2"	45"
BBC45	16 1/2"	48"
BBC48	19 1/2"	51"
Door edge to adjacent corner filler clearance without pulling cabinet from corner.		
<b>FULL OVERLAY</b>	<b>SEMI OVERLAY</b>	
1 3/4"	2 5/8"	

**BLIND CORNER BASE CABINETS**

- Specify blind side left (L) or right (R). Right shown.
- Door hinges to blind side, and will have 90 degree hinging when FOL-C or SOL-C.
- Center stile is 6 3/4" wide: blind opening is 18 3/4"W.
- Cabinet can be pulled 3".
- One 3/4 depth adjustable shelf.
- Inside 1/4" panel covers blind opening.
- Typically requires a 3" filler to adjoining cabinets, provided with cabinet. (Field installation required.)
- When adding rollout to blind cabinets, rollout will pull from blind area into area behind door.

**NOTE:** The adjacent cabinet at right angle to the Blind Base must have an extended stile or filler for proper door and drawer clearance. Hardware pulls will require additional clearance.



**BASE BLIND CORNER CABINETS WITH SWING OUTS**

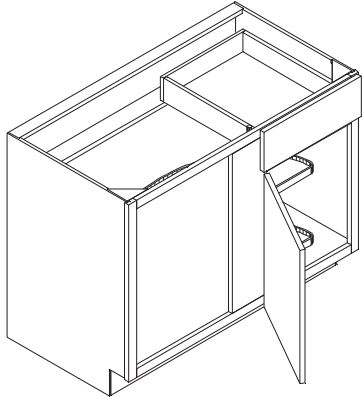

PRODUCT LEVEL 1 LEVEL 2  
CODE

BBSOW42
BBSOW45
BBSOW48

**BBSP NOT available with Inset-Concealed Hinges.**

**BASE BLIND SWING OUT WOOD SHELF CABINET**

- Two wood, half moon trays pivot and slide out independently.

BLIND CORNER CABINET	DOOR OPENING	PULL LIMIT	SHELF DIAM.
42" WIDE	13 1/2"	45"	32
45" WIDE	16 1/2"	48"	35
48" WIDE	19 1/2"	51"	38

**NOTE:** The adjacent cabinet at right angle to the Blind Base must have an extended stile or filler for proper door and drawer clearance. Hardware pulls will require additional clearance.

**BASE BLIND CORNER CABINETS w/ SWING OUTS**

- Specify blind side left (L) or right (R). Left blind shown.
- Door hinges to blind side, and will have 90 degree hinging when FOL-C or SOL-C.
- Center stile is 6 3/4" wide, blind opening is 18 3/4"W. Cabinet can be pulled 3".
- Inside 1/4" panel covers blind opening.
- Typically requires a 3" filler to adjoining cabinets, provided with cabinet. (Field installation required.)
- Check for availability with the factory if extending stile in or making a change that reduces the frame opening or cabinet depth.

Door edge to adjacent corner filler clearance without pulling cabinet from corner:	
<b>FULL OVERLAY</b>	<b>SEMI OVERLAY</b>
1 3/4"	2 5/8"

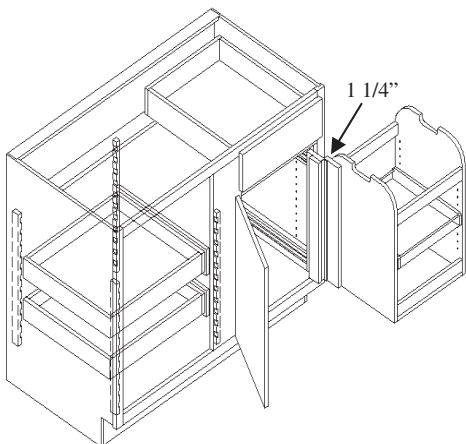

BBSP42
BBSP45
BBSP48

**NOT recommended for use next to oven.**

**BASE BLIND SWING OUT, PULL OUT CABINET**

- Can good unit will not be attached to door, pull out and swing away from blind area.
- Two rollouts pull from blind area into space behind door.



NOTES

**BASE SINK CABINETS**

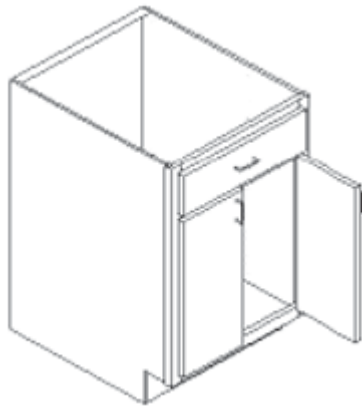

**SINK BASE CABINETS, ONE FALSE DRAWER**

- One false top drawer.
- Specify hinge side on single door cabinets.

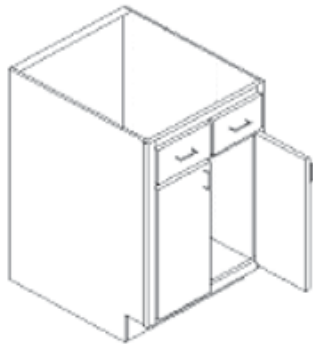

**SINK BASE CABINET, TWO FALSE DRAWERS**

- Two false top drawers.
- When ordering soap tray, both false drawer fronts will have soap trays.

PRODUCT LEVEL 1 LEVEL 2  
CODE

One drawer,  
one door

BS18

BS21

BS24

One drawer,  
two doors

BS1D24-2

BS1D27

BS1D30

BS1D33

BS1D36

BS1D39

BS1D42

Two drawers,  
two doors

BS24-2

BS27

BS30

BS33

BS36

BS39

BS42

BS45

BS48

**BASE FARMER SINK**

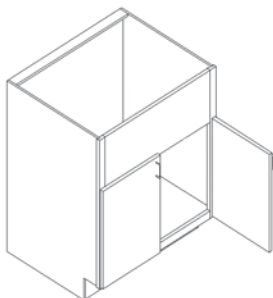

Two doors

BFS27

BFS30

BFS33

BFS36

BFS39

BFS42

**BASE FARMER SINK**

- No false top drawer front.
- 11 1/2" solid top rail is standard. Overlay cabinets will have approximately 10" exposed above doors. Specify if change is needed to allow more space for the sink apron for no upcharge.
- Factory cutout in top rail not available. Any cutout must be done in the field with the sink on site.

**BASE SINK CABINETS, FULL HEIGHT DOOR**

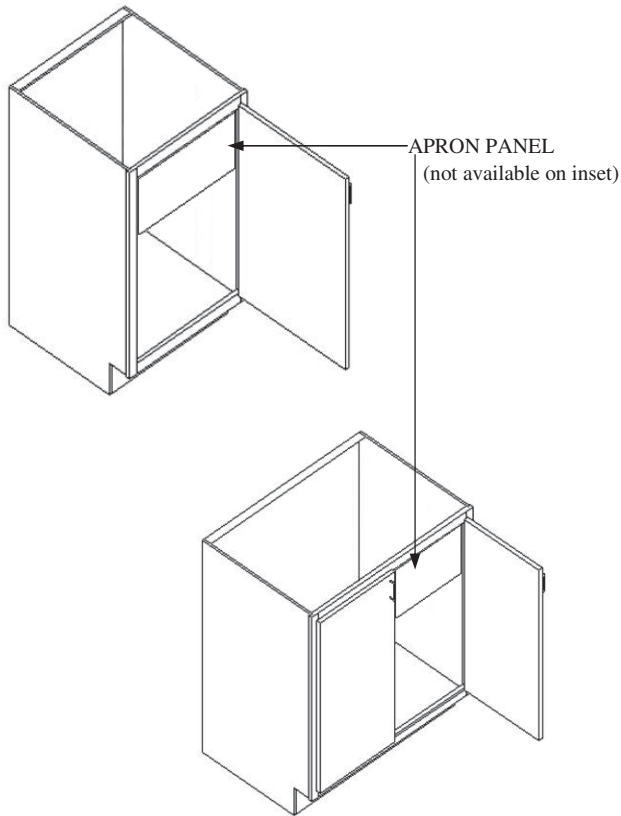

	PRODUCT CODE	LEVEL 1	LEVEL 2
ONE DOOR	BSFD18		
	BSFD21		
	BSFD24-1		
TWO DOOR	BSFD24-2		
	BSFD27		
	BSFD30		
	BSFD33		
	BSFD36		
	BSFD39		
	BSFD42		
	BSFD45		
	BSFD48		

**BASE SINK CABINET WITH FULL HEIGHT DOORS**

- 24" deep
- Specify hinge side for single door cabinet
- FOL and SOL cabinets will have a 1/4" apron panel attached at the top, behind the face frame
- The apron panel will match the frame specie and finish, and will have the same approximate height as a false top drawer front
- Inset cabinets cannot have an apron panel to hide the sink bowl

**BASE RADIUS SINKS**

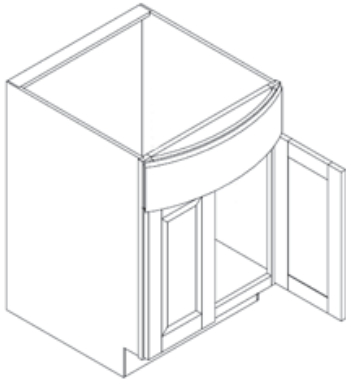

**Please send for a Custom quote if any of the following apply:**

- Cabinet height is modified above 42"
- Cabinet width or depth is changed
- Another cabinet configuration is wanted
- MDF door style is chosen (Summit MDF not available)
- See general accessories for radius molding offerings

PRODUCT CODE	LEVEL 1	LEVEL 2
BSRD30		
BSRD33		
BSRD36		

BSRD30		
BSRD33		
BSRD36		

**BASE SINK WITH RADIUS DRAWER FRONT**

- 24" deep, 34 1/2" high standard.
- Single radius drawer front above 2 non-radius doors.
- Radius portion of face frame has a 3" rise. Example: 24" deep BSRD30 has 24" deep case sides with a 27" overall depth to center of radius face frame.
- Tiltout drawer fronts are not available.
- Radius cabinets may ship separately from the rest of the order. Extended lead times apply.
- The following door styles are not available: Cafe, Craftsman, Cottage, Lakeland, LaPorte, Lincoln, Madrid, Newport, Prairie, Sardinia, Valletta, Verona, Woodridge, or Zenith. If ordering Churchill-Inset, top drawer front is not available for 5 piece and must be slab.
- Furniture ends not available.

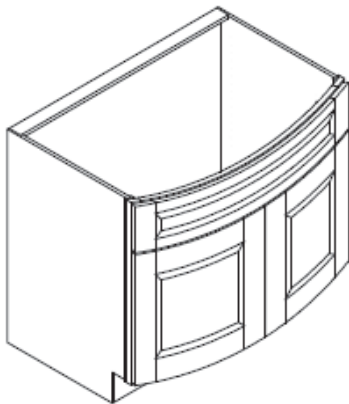

**Please send for a Custom quote if any of the following apply:**

- Cabinet height is modified above 42"
- Cabinet width or depth is changed
- Another cabinet configuration is wanted
- MDF door style is chosen (Summit MDF not available)
- See general accessories for radius molding offerings

BRS1D30		
BRS1D33		
BRS1D36		

**BASE RADIUS SINK, ONE FALSE DRAWER AND TWO DOORS**

- 24" deep, 34 1/2" high standard.
- Side door reveals are adjusted to allow operation of doors and drawers on adjacent cabinets.
- Face frame has a 3" rise. Example: 24" deep BRS1D30 has 24" deep case sides with a 27" overall depth to center of face frame.
- Standard recessed toe will be squared.
- Tilt-out fronts are not available.
- Radius cabinets may ship separately from the rest of the order. Extended lead times apply.
- The following door styles are not available: Cafe, Craftsman, Cottage, Lakeland, LaPorte, Lincoln, Madrid, Newport, Prairie, Sardinia, Valletta, Verona, Woodridge, or Zenith. If ordering Churchill-Inset, top drawer front is not available for 5 piece and must be slab.
- Furniture ends not available.

BASE SINK POST NOTCH, 27" DEEP

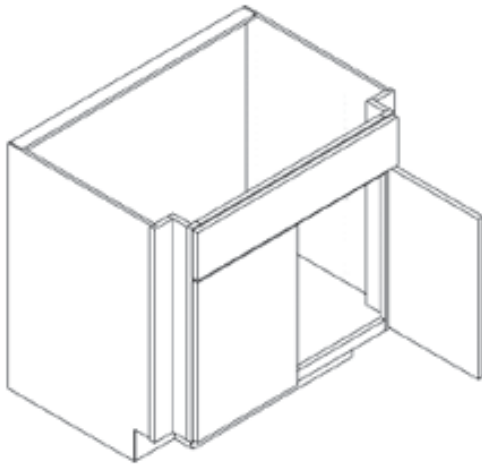

	PRODUCT CODE	LEVEL 1	LEVEL 2
One drawer, two doors	BSPN1D27		
	BSPN1D30		
	BSPN1D33		
	BSPN1D36		
	BSPN1D39		
	BSPN1D42		
	BSPN1D45		
	BSPN1D48		

**BASE SINK POST NOTCH, ONE FALSE DRAWER**

- One false top drawer.
- Post notch will be standard 3" wide and 3" deep on each side to align with standard base cabinet depth of 24"
- Specify if for post size other than 3" wide X 3" deep

**NOTE:** Modifying the depth of the post notch will cause this cabinet to not align with a 24" deep cabinet unless the cabinet depth is modified.

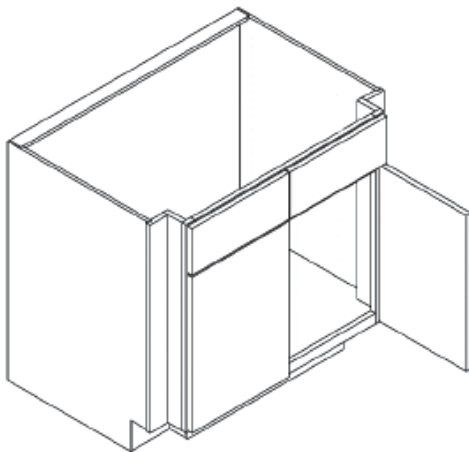

Two drawers, two doors	BSPN27		
	BSPN30		
	BSPN33		
	BSPN36		
	BSPN39		
	BSPN42		
	BSPN45		
	BSPN48		

**BASE SINK POST NOTCH, TWO FALSE DRAWERS**

- Two false top drawers.
- Post notch will be standard 3" wide and 3" deep on each side to align with standard base cabinet depth of 24"
- Specify if for post size other than 3" wide X 3" deep

**NOTE:** Modifying the depth of the post notch will cause this cabinet to not align with a 24" deep cabinet unless the cabinet depth is modified.

BASE SINK CLIP CORNER, 27" DEEP

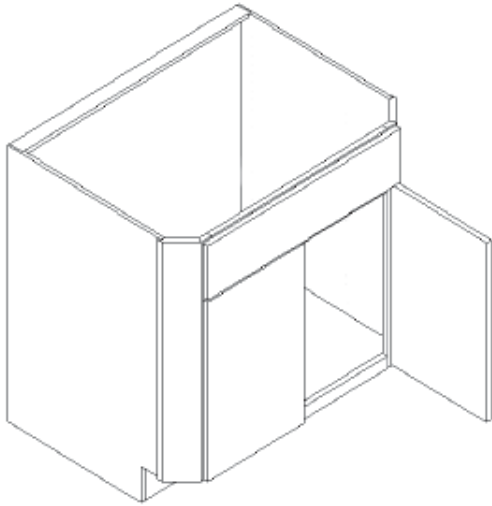

	PRODUCT CODE	LEVEL 1	LEVEL 2
One drawer, two doors	BSCC1D27		
	BSCC1D30		
	BSCC1D33		
	BSCC1D36		
	BSCC1D39		
	BSCC1D42		
	BSCC1D45		
	BSCC1D48		

**BASE SINK CLIP CORNER, ONE FALSE DRAWER**

- One false top drawer.
- Clips reduce width of face front by 3" on each side.
- Clips reduce depth of case sides by 3" on each side.

**NOTE:** Modifying the width of the clipped corner will cause this cabinet to not align with a 24" deep cabinet unless the cabinet depth is modified.

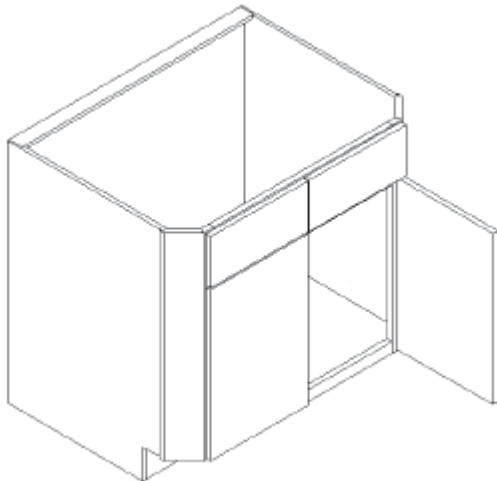

Two drawers, two doors	BSCC27		
	BSCC30		
	BSCC33		
	BSCC36		
	BSCC39		
	BSCC42		
	BSCC45		
	BSCC48		

**BASE SINK CLIP CORNER, TWO FALSE DRAWERS**

- Two false top drawers.
- Clips reduce width of face front by 3" on each side.
- Clips reduce depth of case sides by 3" on each side.

**NOTE:** Modifying the width of the clipped corner will cause this cabinet to not align with a 24" deep cabinet unless the cabinet depth is modified.



**BASE CABINET WITH ROLLOUTS**

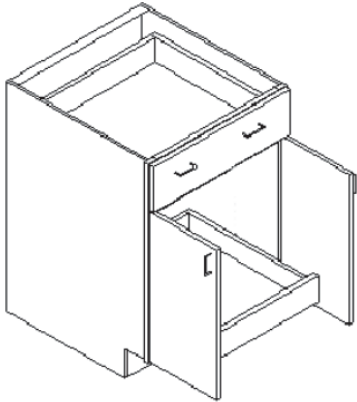

**BASE CABINET WITH ROLLOUTS**

- Adjustable, full width, 4” high rollouts
- Specify hinge side for single door cabinets.
- Adjustable shelf not included.
- Rollouts not recommended for cabinets less than 15” wide.
- Rollouts not available for cabinets less than 9” wide or 12” deep.

See Rollout Shelves listed in Base accessories for more specific rollout details.

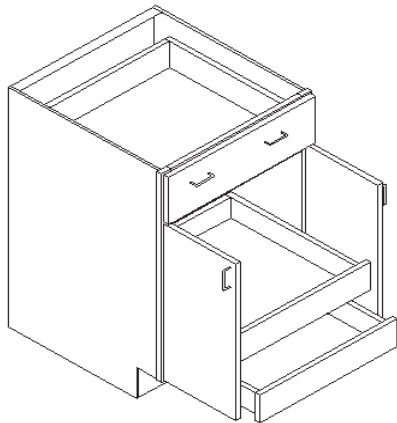

	PRODUCT CODE	LEVEL 1	LEVEL 2
	One 4” rollout		
One door	B15+RO1		
	B18+RO1		
	B21+RO1		
	B1D24+RO1		
Two doors	B1D24-2+RO1		
	B1D27+RO1		
	B1D30+RO1		
	B1D33+RO1		
	B1D36+RO1		
	B1D39+RO1		
	B1D42+RO1		
	Two 4” rollouts		
One door	B15+RO2		
	B18+RO2		
	B21+RO2		
	B1D24+RO2		
Two doors	B1D24-2+RO2		
	B1D27+RO2		
	B1D30+RO2		
	B1D33+RO2		
	B1D36+RO2		
	B1D39+RO2		
	B1D42+RO2		

BASE CABINET WITH ROLLOUTS

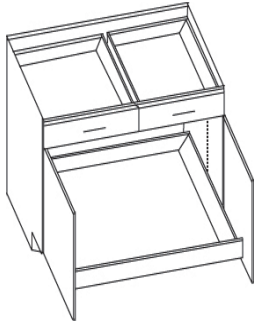

- One adjustable, full width, 4" high rollout.
- Adjustable shelf not included.

See Rollout Shelves listed in Base accessory section for more specific rollout details.

	PRODUCT CODE	LEVEL 1	LEVEL 2
Two drawer / Two door	One 4" rollout		
	B27+RO1		
	B30+RO1		
	B33+RO1		
	B36+RO1		
	B39+RO1		
	B42+RO1		

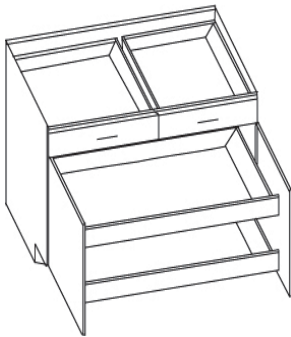

- Two adjustable, full width, 4" high rollouts.
- Adjustable shelf not included.

See Rollout Shelves listed in Base accessory section for more specific rollout details.

Two drawer / two door	Two 4" rollouts		
	B27+RO2		
	B30+RO2		
	B33+RO2		
	B36+RO2		
	B39+RO2		
	B42+RO2		

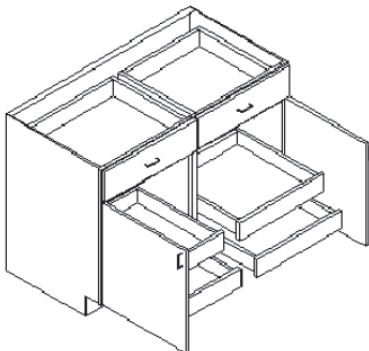

- Adjustable, full width, 4" high rollouts.
- Illustration shows two rollouts per side for four rollouts total.
- Center partition separates rollouts.
- Adjustable shelf not included.

See Rollout Shelves listed in Base accessory section for more specific rollout details.

One rollout / side Two drawer / two door	4" rollouts		
	B45+RO2		
	B48+RO2		
Two rollouts / side Two drawer / two door	B45+RO4		
	B48+RO4		



**BASE WASTE CABINET**

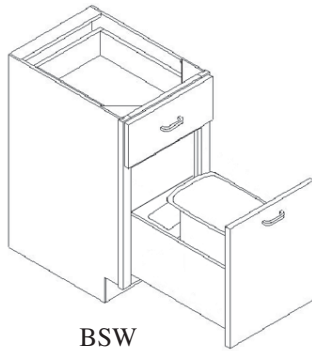

BSW

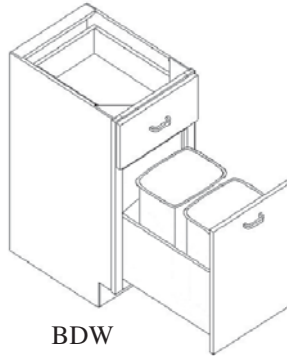

BDW

- Undermount soft close glides on pullout.
- Pullout attached to door.
- Specify basket color; W = white, P = pewter.
- Fixed floor below the top drawer box (BSW and BDW only)
- Minimum cabinet depth = 24".
- Minimum single waste basket cabinet width = 15". Reduced widths may be available by quote only.
- Minimum double waste basket cabinet width = 18". Reduced widths may be available by quote only.
- Extra storage space behind waste can in single basket cabinet.
- 30 lbs. maximum per waste can. Not intended for bulk storage.
- See chart for waste basket sizes.
- All illustrations are of FOL-C style waste basket cabinets.

PRODUCT LEVEL 1 LEVEL 2  
CODE

Waste Cabinet w/ top dr. box and white baskets	BSW15W
	BSW18W
	BDW18W
	BDW21W
Waste Cabinet w/ top dr. box and pewter baskets	BSW15P
	BSW18P
	BDW18P
	BDW21P

**NOTE:** Standard size trash can will not fit into frame opening of reduced height BSW or BDW. Please use BSWFD or BDWFD. Reduced height cabinet may receive smaller waste bins than standard.

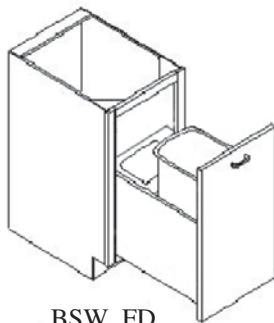

BSW\_FD

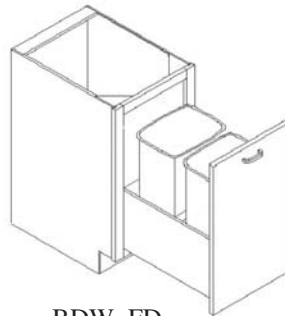

BDW\_FD

Full Height Door with white baskets	BSW15FDW
	BSW18FDW
	BDW18FDW
	BDW21FDW
Full Height Door with pewter baskets	BSW15FDP
	BSW18FDP
	BDW18FDP
	BDW21FDP

Cabinet	Bin Qty./Size
BSW15	One 35 Qt bin
BSW18	One 35 Qt bin
BDW18	Two 35 Qt bins
BDW21	Two 35 Qt bins
BSW15FD	One 50 Qt bin
BSW18FD	One 50 Qt bin
BDW18FD	Two 50 Qt bins
BDW21FD	Two 50 Qt bins



# NOTES

BASE 2 EQUAL DRAWER BASE

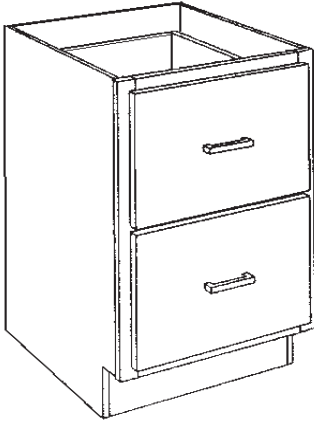

- Two equal height drawer fronts
- Two 10" deep drawer boxes
- Will accommodate hanging files, add AHANGINGFILE accessory per drawer.

PRODUCT CODE	LEVEL 1	LEVEL 2
--------------	---------	---------

B2ED12		
--------	--	--

B2ED15		
--------	--	--

B2ED18		
--------	--	--

B2ED21		
--------	--	--

B2ED24		
--------	--	--

B2ED27		
--------	--	--

B2ED30		
--------	--	--

BASE 2-SEED DRAWER CABINET

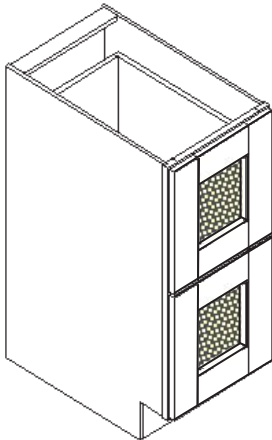

PRODUCT CODE	LEVEL 1	LEVEL 2
--------------	---------	---------

B2SD15		
--------	--	--

B2SD18		
--------	--	--

B2SD21		
--------	--	--

**NOTE:** Due to limitations; Cumberland, Hamilton, LaSalle, Lincoln, Woodridge, and Zenith door styles are NOT AVAILABLE for this cabinet. When selecting these door styles a Shaker door with L-059 outside profile will be substituted with the exceptions of Woodridge which will have an LC-Inset outside profile and Zenith which will have a machine outside profile.

- Two drawer boxes, 10" deep.
- Drawer fronts made with 3 1/2" wide stiles and rails.
- Plexiglass will be installed in drawer fronts at factory.
- There is a 1" opening between the drawer box front and the partition that separates the seed area from the storage area of the drawer. (Partition is removable)
- All top to bottom drawer front reveals will be 1/4", side reveals will be same as overlay ordered.

**BASE 3 DRAWER CABINET**

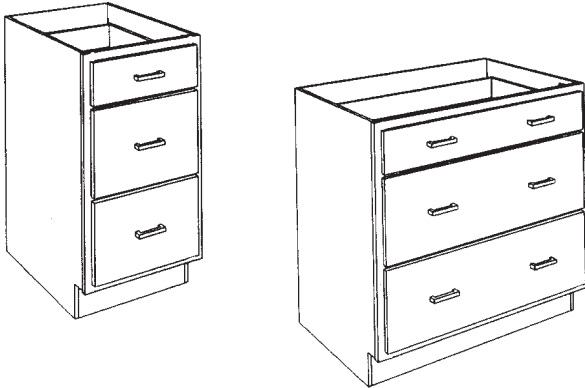

**BASE 3 DRAWER CABINET**

- 4” high standard top drawer box.
- Two 8” high lower drawer boxes.

PRODUCT CODE	LEVEL 1	LEVEL 2
B3D12		
B3D15		
B3D18		
B3D21		
B3D24		
B3D27		
B3D30		
B3D33		
B3D36		
B3D39		
B3D42		

**BASE 4 DRAWER CABINET**

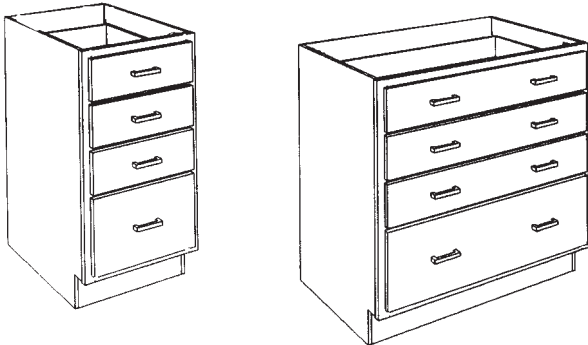

**BASE 4 DRAWER CABINET**

- Top three drawer boxes are 4” high standard.
- Larger 6” high drawer box at bottom position is standard.
- Specify location of larger drawer if other than bottom is required.  
(Add modification, MFC, for frame change.)

B4D12		
B4D15		
B4D18		
B4D21		
B4D24		
B4D27		
B4D30		
B4D33		
B4D36		
B4D39		
B4D42		

BASE WITH 2 TOP DRAWERS, 4 DRAWER CABINET

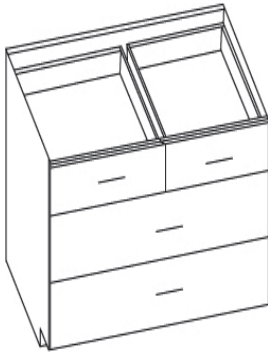

- Two side by side, 4" high, standard top drawer boxes
- Two 8" high lower drawer boxes

PRODUCT CODE	LEVEL 1	LEVEL 2
B2T4D24		
B2T4D27		
B2T4D30		
B2T4D33		
B2T4D36		
B2T4D39		
B2T4D42		

BASE CORNER 3 DRAWER BANK CABINET

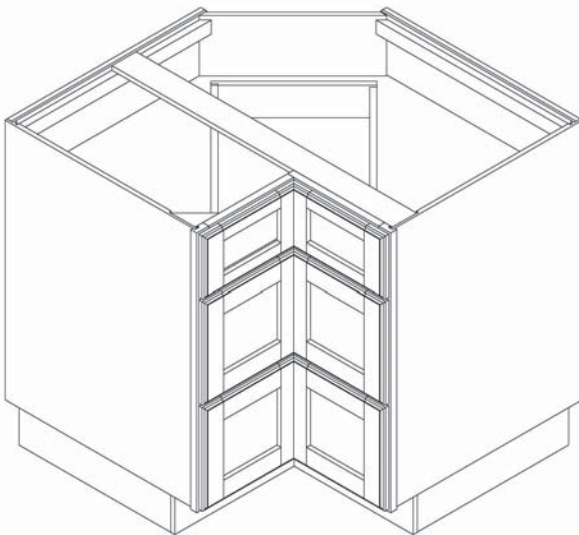

- Pie cut corner cabinet with three functional drawers
- Available with 36" wide left and right legs only. Any changes MUST be quoted
- Not available in Inset
- Drawer fronts will always overlay 1/2" on each side
- Fixed center floors between each drawer.
- Shipped with loose toe base. SEE NEXT PAGE FOR TOE KICK INSTALLATION INFORMATION

PRODUCT CODE	LEVEL 1	LEVEL 2
BC3DB36		

**BASE PIE CUT INFORMATION**

**TOE KICK ASSEMBLY**

1. Remove doors and adjustable shelves.
2. Turn cabinet upside down.
3. Place both sections of toe kick as shown, with triangular corner blocks against the floor of the cabinet. Then screw through the 1/2" corner supports into the cabinets' floor using 1" pan head screws.
4. The shorter "legs" of both sections should be 90° to each other.
5. The longer "legs" of the two sections are placed against the backs of the cabinet, as close to the rear corner as possible.
6. The section's two short legs butt together as shown in the magnification.
7. Attach the two sections together with small nails or staples at this joint if needed.
8. Stand cabinet to upright position and reinstall shelves and doors.

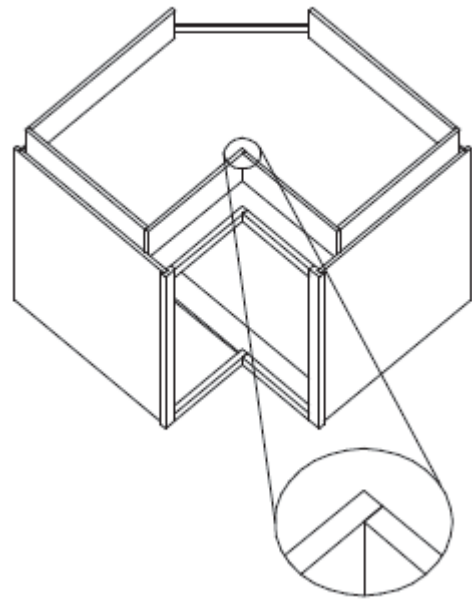

**RECOMMENDED HARDWARE INSTALLATION**

Countersink all screws to prevent frame or adjacent cabinet damage when closing or opening doors.

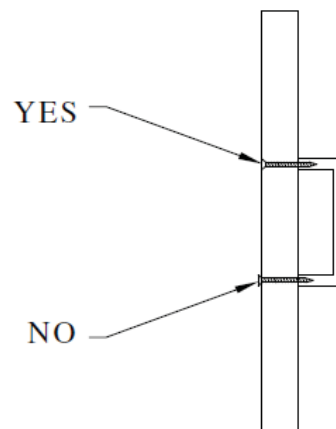



**BASE PIE CUT CABINETS**

**BASE PIE CUT CORNER CABINET**

- BPCA'S have one adjustable shelf.
- Specify hinge side. (No partition available on same side as hinging.)
- Shipped with loose toe base.
- Depending on door style, cabinets with legs less than 36" may require us to substitute a slab door due to minimum size requirements. (See specific door styles.)

\* This dimension is approximately 12".

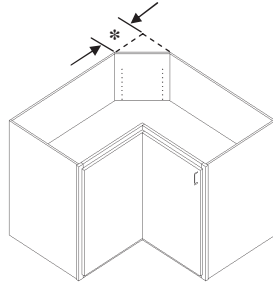

PRODUCT CODE	LEVEL 1	LEVEL 2
BPCA33		
BPCA36		
BPCA39		
BPCA3336		
BPCA3633		
BPCA3639		
BPCA3936		

BPCA33
BPCA36
BPCA39
BPCA3336
BPCA3633
BPCA3639
BPCA3936

**NOTES**

- Pie cut cabinets with offset dimensions will list the left width first in the product nomenclature followed by the right width. Example: BUSP3633 has a left width of 36" and a right width of 33".
- It is recommended that all hardware screws are countersunk into the back of the door to avoid possible damage to the cabinet face frame.

**BASE ULTRA SUSAN PIE CUT CORNER**

- BUSP'S have one adjustable shelf and two turntables.
- Specify hinge side. (No partition available on same side as hinging.)
- Shipped with loose toe base.
- Depending on door style, cabinets with legs less than 36" may require us to substitute a slab door due to minimum size requirements. (See specific door styles.)

\* This dimension is approximately 12".

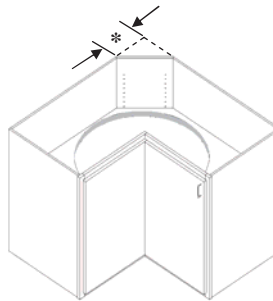

BUSP33
BUSP36
BUSP39
BUSP3336
BUSP3633
BUSP3639
BUSP3936

**BASE REVOLVING DOOR PIE CUT CORNER**

- For use in a 36" x 36" corner space only. Dimensions cannot be modified.
- Equal doors attached to shelving hardware that revolves into cabinet as one unit. Slab doors illustrated.
- Bottom and centered pie cut shelves.
- Revolving shelves are polymer.
- Shipped with loose toe base.

BRDP36
--------

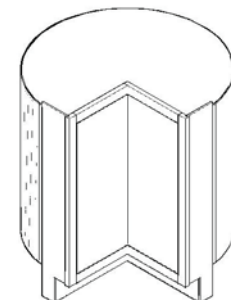

**BASE DIAGONAL CORNER CABINET**

**BASE DIAGONAL CORNER, ADJUSTABLE SHELF**

- BDCA'S have one adjustable shelf
- Specify hinge side
- Shipped with loose toe base

PRODUCT LEVEL 1 LEVEL 2  
CODE

BDCA33
BDCA36
BDCA39

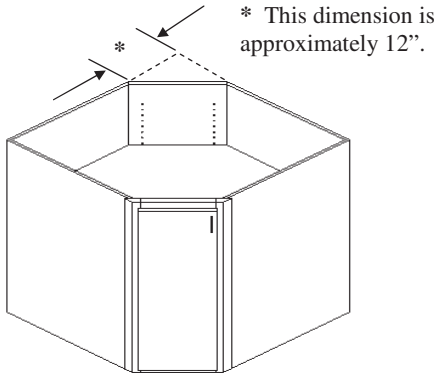

	WALL RUN	FRONT DIMENSION
BDCA33	33"	12 11/16"
BDCA36	36"	16 15/16"
BDCA39	39"	21 3/16"
BUSD33	33"	12 11/16"
BUSD36	36"	16 15/16"
BUSD39	39"	21 3/16"

**BASE ULTRA SUSAN DIAGONAL CORNER (not pictured)**

- BUSD'S have 1 adjustable shelf and 2 turn tables
- Specify hinge side
- Shipped with loose toe base

BUSD33
BUSD36
BUSD39

**BASE DIAGONAL INSTALLATION INFORMATION**

**TOE KICK ASSEMBLY**

1. First place both sections down as shown , with triangular corner brace blocks at top.
2. The back support of the two sections is placed against the back of the cabinet, as far into the rear corner as possible.
3. The first support of the two sections is placed to the front of the cabinet so that there is 3 1/2" from the front of the face frame to the face of the front support.

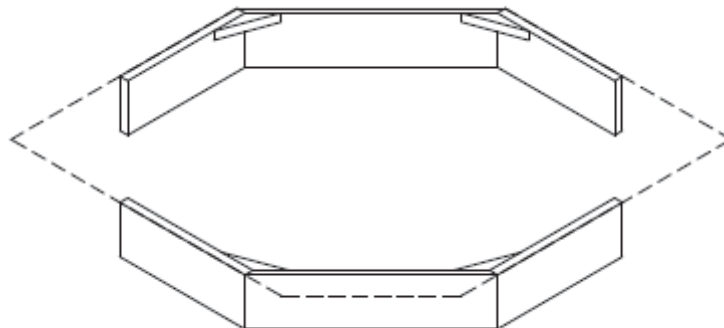

BASE ANGLED SINK FRONT

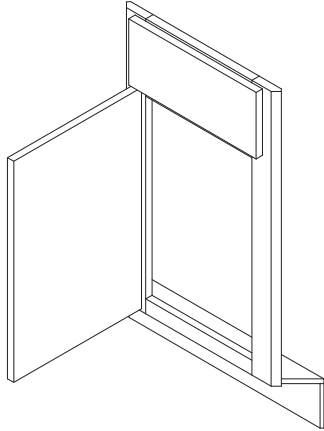

BASE ANGLED SINK FRONT

PRODUCT CODE	LEVEL 1	LEVEL 2
BASF36		
BASF39		
BASF42-2		

- 34 1/2" high standard.
- Typical 24" deep application.
- Base front can have loose floor, **not included**.
- BASF42-2 only available with butt doors.

**BASF FLOOR**

- Floor will ship at size of 1" bigger than cabinet ordered.
- Field trimming is required.

LOOSE FLOOR

FOR BASF36  
FOR BASF39  
FOR BASF42-2

BASFFLOOR3737
BASFFLOOR4040
BASFFLOOR4343

**BASE CORNER SINK CABINETS**

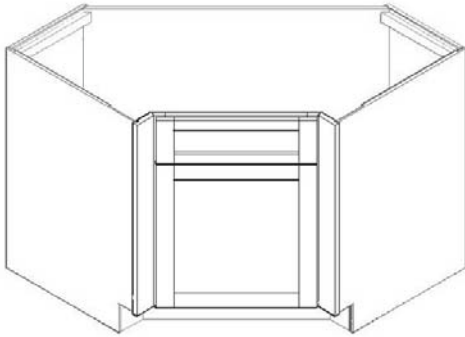

PRODUCT LEVEL 1 LEVEL 2  
CODE

Drawer / door	BSCS42
---------------	--------

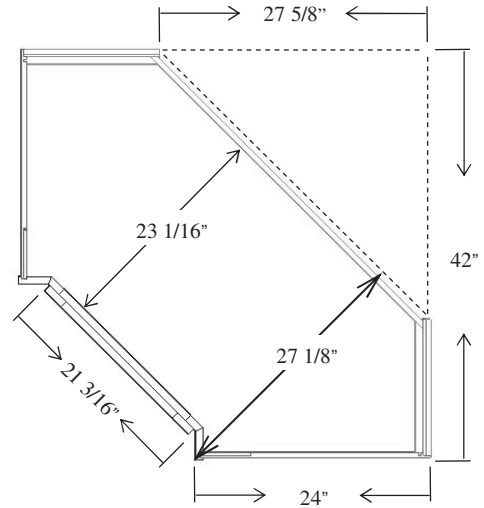

**BASE SHALLOW CORNER SINK**

- Reduced depth to allow transit through narrow doorway
- False drawer front above single door
- Specify left (L) or right (R) hinge.
- Integrated toe base
- 4" deep recessed front
- Two side frame 'wings' set at 135°, each measuring 3" wide.
- ATR (towel rack) is not recommended for installation due to sink clearance.

**BASE DIAGONAL INSTALLATION INFORMATION**

**TOE KICK ASSEMBLY**

1. First place both sections down as shown , with triangular corner brace blocks at top.
2. The back support of the two sections is placed against the back of the cabinet, as far into the rear corner as possible.
3. The first support of the two sections is placed to the front of the cabinet so that there is 3 1/2" from the front of the face frame to the face of the front support.

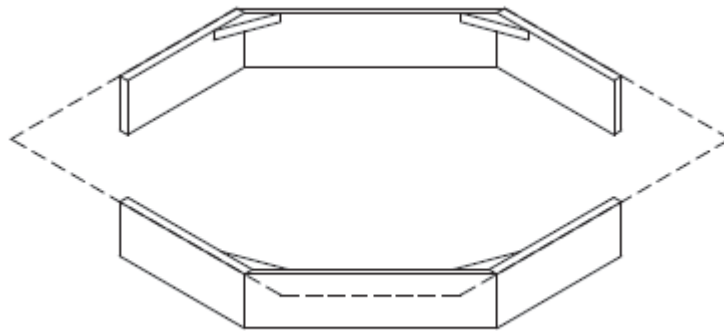

## BASE CORNER SINK CABINETS

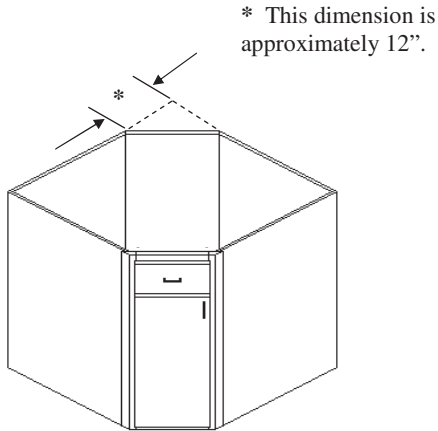

### BASE DIAGONAL SINK

- Shipped with loose toe base.
- ATR (towel rack) is not recommended for installation due to sink clearance.

**\*\*Note:** BDS42-2 and BDSFD42-2 are only available with 2-butt doors.

PRODUCT CODE	LEVEL 1	LEVEL 2
Drawer / door	BDS36	
	BDS39	
	BDS42-2**	
Full height door (not pictured)	BDSFD36	
	BDSFD39	
	BDSFD42-2**	

	WALL RUN	FRONT DIMENSION
BDS36	36"	16 15/16"
BDS39	39"	21 3/16"
BDS42-2	42"	25 7/16"
BDSFD36	36"	16 15/16"
BDSFD39	39"	21 3/16"
BDSFD42-2	42"	25 7/16"

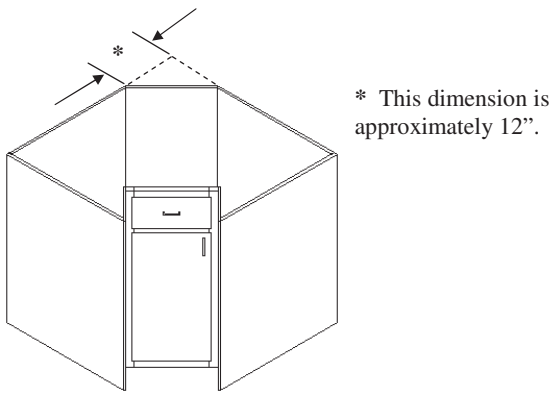

### BASE RECESSED CORNER SINK

- 4" deep recessed front.
- Shipped with loose toe base.
- ATR (towel rack) is not recommended for installation due to sink clearance.

	WALL RUN (A)	FRONT DIMENSION (B)
BRCS36	36"	16 5/8"
BRCS39	39"	20 7/8"
BRCS42-2	42"	25 1/8"
BRCS45-2	45"	29 3/8"

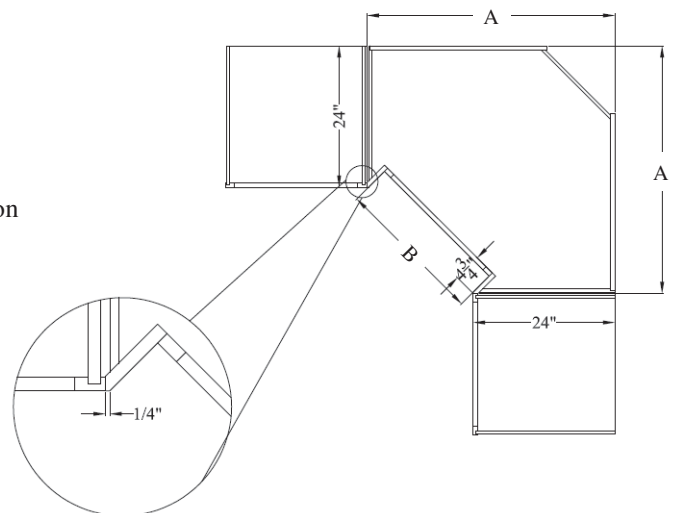

BRCS36
BRCS39
BRCS42-2
BRCS45-2

BRCS42-2 and BRCS45-2 are only available with 2-butt doors.

# BOC

## Base Oven Cabinet

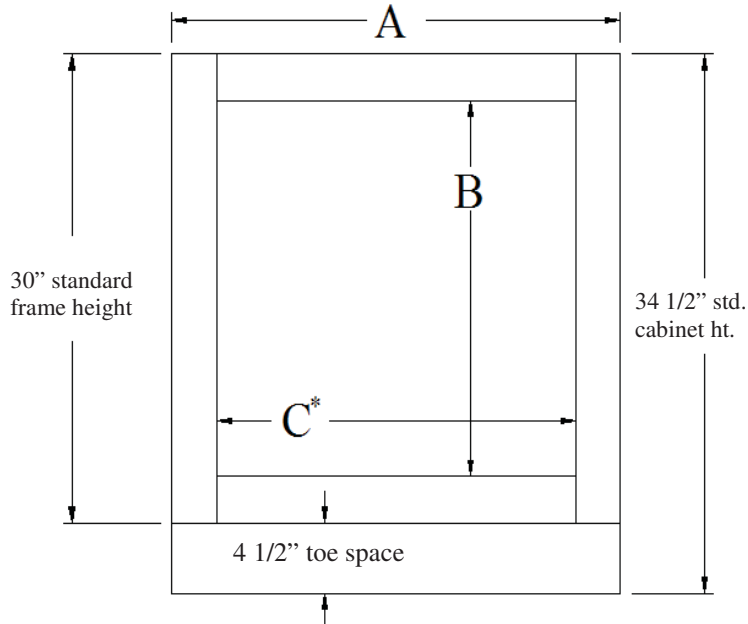

Provide the following dimensions:	
A= _____	Overall cabinet width
B= _____	Oven cutout height
C*= _____	Oven cutout width
*Cutout may be no wider than 1 1/2" less the overall cabinet width, see chart	

- Minimum top rail width of 5/8"
- Maximum standard overall oven cutout height of 27 7/8".
- Oven cutout is centered when 27" high or less unless otherwise specified.
- Minimum height oven cutout to start from floor is 5 1/4". MFC (frame change) charge applies if cutout starts less than 5 1/4" from floor.
- Appliance cutout opening not beaded for beaded Inset style cabinet.

### \*Max cutout widths

Cabinet width	Max cutout width
24"	22 1/2"
27"	25 1/2"
30"	28 1/2"
33"	31 1/2"
36"	34 1/2"

**NOTE:** Appliance openings in frames will not have a beaded perimeter when ordered on beaded inset cabinetry. Designer must specify in writing if the appliance opening is to have a bead.

**BASE OVEN CABINET**

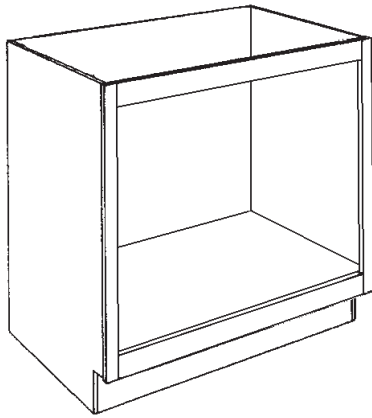

PRODUCT CODE	LIST PRICE
BOC27	
BOC30	
BOC33	
BOC36	

NOTE: BOC cabinet cannot have decorative ends except for a standard flush finish when using maximum width cutout for the specific cabinet's overall width.

**BASE OVEN CABINET**

- Designed for under-counter ovens and appliances.
- Specify oven cutout width x height, and height off floor. Use of template page for BOC is recommended.
- Cutout will be centered unless otherwise specified.
- If a finished side is required, flush finished ends must be used, due to construction methods.
- See template page for more details.
- Appliance openings in frames will not have a beaded perimeter when ordered on beaded inset cabinetry. Designer must specify in writing if the appliance opening is to have a bead.

**BASE APPLIANCE PLATFORMS**

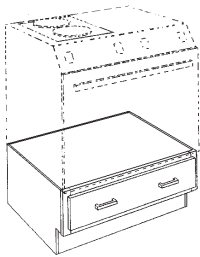

**BASE APPLIANCE PLATFORM DRAWER**

- Full width functional drawer.
- Specify height dimension.
- Minimum overall height is 12 1/4".
- Top rail is 2 1/4" standard.
- Can also be used as dishwasher or microwave platform.
- 3/4" flush top that matches the cabinet interior.

PRODUCT CODE	LEVEL1	LEVEL2
BAPD24		
BAPD27		
BAPD30		
BAPD33		
BAPD36		

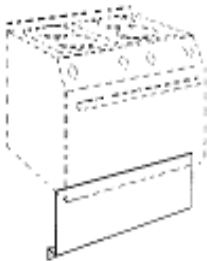

**BASE APPLIANCE TOE PLATE**

- BATP is 30" wide, 14" high.
- Specify if other dimension is needed.

BATP3014
----------

# BMOCC

## Base Microwave Oven Cabinet

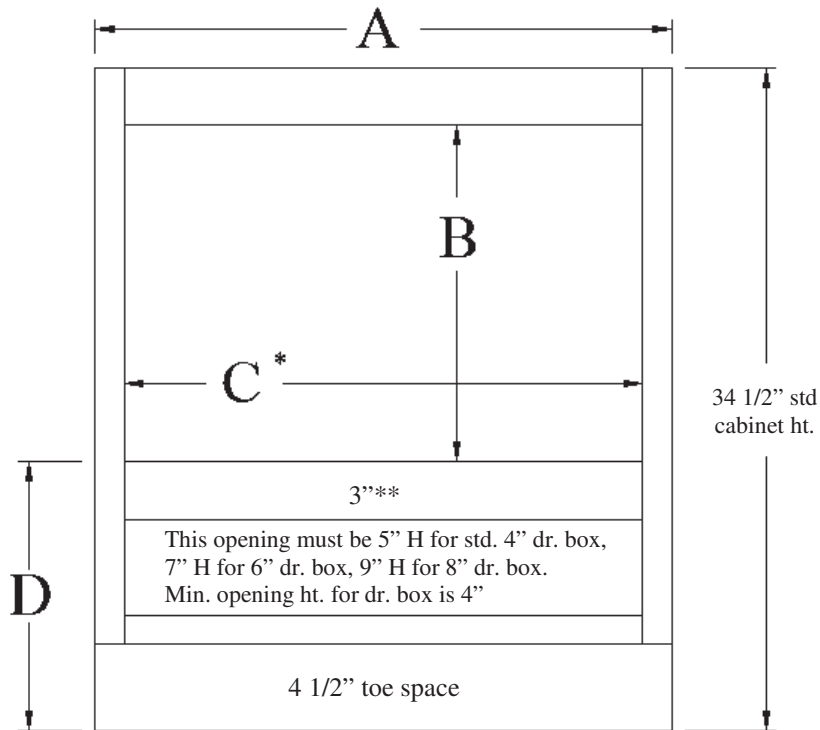

Provide the following dimensions:	
A= _____	Overall cabinet width
B= _____	Oven cutout height
C*= _____	Oven cutout width
D= _____	Height cutout to start from floor (recommended min. ht. = 14")

- 3" middle rail standard unless specified.
- Minimum top rail width of 5/8".
- Cutout height cannot exceed 20" to allow for standard 4" high drawer box.
- \*Cutout may be no wider than 1 1/2" less the overall cabinet width, see chart.
- Cutout centered side to side unless specified.
- Appliance cutout opening not beaded for beaded Inset style cabinet.

### \*Max cutout widths

Cabinet width	Max cutout width
24"	22 1/2"
27"	25 1/2"
30"	28 1/2"
33"	31 1/2"
36"	34 1/2"

\*\*For figuring reveals for install kits, drawer fronts overlay the oven rails by the following standard amounts:

Hinge	Overlay
FOL-C	1 1/4"
SOL-C/SOL-K	1/2"
SOL-K Lipped	5/16"
<b>Specify if another dimension is desired***</b>	

\*\*\*SOL-K Lipped overlays cannot be modified

**NOTE:** Appliance openings in frames will not have a beaded perimeter when ordered on beaded inset cabinetry. Designer must specify in writing if the appliance opening is to have a bead.



**BASE MICROWAVE OVEN CABINETS**

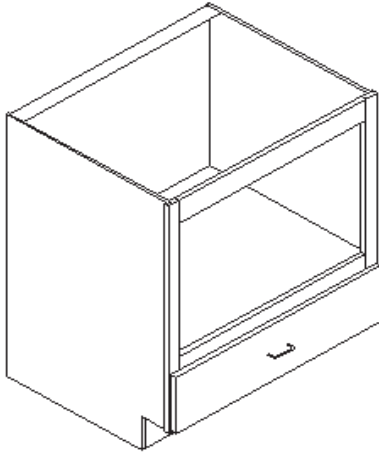

PRODUCT CODE	LEVEL 1	LEVEL 2
BMOC24		
BMOC27		
BMOC30		

NOTE: BMOC cabinet cannot have decorative ends except for a standard flush finish when using maximum width cutout for the specific cabinet's overall width.

**BASE MICROWAVE OVEN CABINET**

- 3" middle rail standard.
- Specify oven cutout width x height and height off floor. Use of template page for BMOC is recommended.
- BMOC has functional drawer at bottom.
- Interior of cutout is same specie and stain as frame.
- To allow for standard 4" height drawer box, the cutout must start at least 14" off of floor.
- If a finished side is required, flush finished ends must be used, due to construction methods.
- See template page for more details.
- Appliance openings in frames will not have a beaded perimeter when ordered on beaded inset cabinetry. Designer must specify in writing if the appliance opening is to have a bead.

**BASE DOWN DRAFT CABINET**

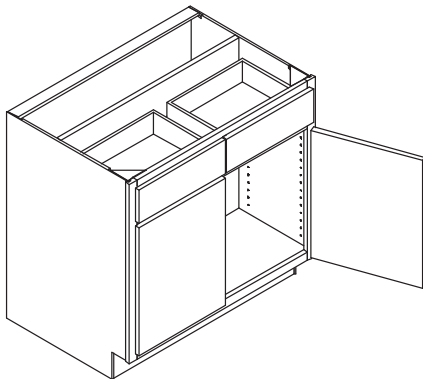

TOP VIEW

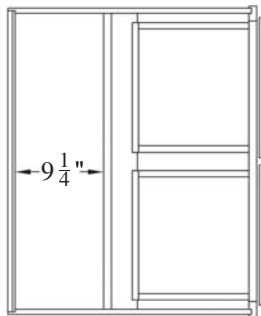

BDDC30
BDDC33
BDDC36
BDDC39
BDDC42
BDDC45
BDDC48

**BASE DOWN DRAFT CABINET**

- One adjustable, shallow depth shelf.
- Downdraft area clearance is 9 1/4".
- See base modifications for adding scooped top drawer modification.
- Functional, 1/2 depth drawers.
- Removable divider allows access to down draft area.
- Cabinets 39" wide or greater will have a fixed center stile as standard.

# BWDC

## Base Warming Drawer Cabinet

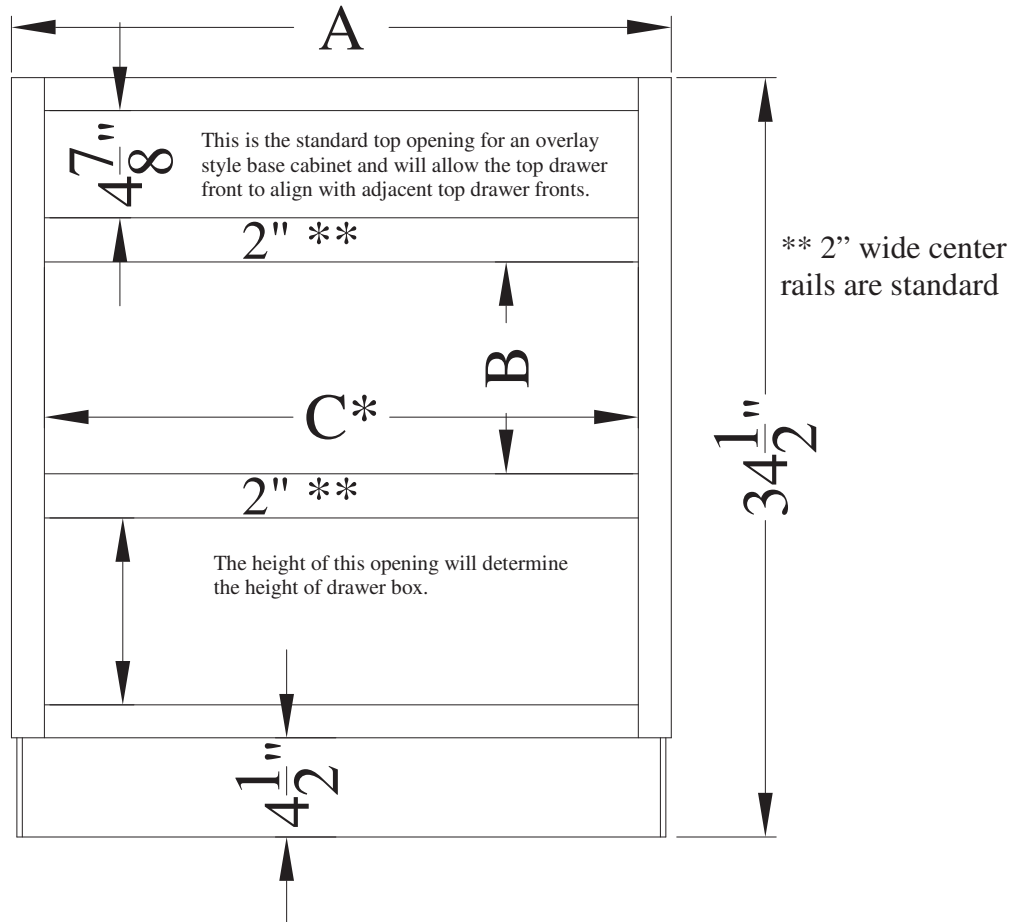

Provide the following dimensions:
A= _____ Overall cabinet width
B= _____ Oven cutout height
C*= _____ Oven cutout width
*Cutout may be no wider than 1 1/2" less the overall cabinet width, see chart

Cabinet width	Max cutout width
24"	22 1/2"
27"	25 1/2"
30"	28 1/2"
33"	31 1/2"
36"	34 1/2"

- 2" rails above and below warming drawer cutout.
- Top frame opening will be 5 1/4" high to align with standard Inset style base cabinets.
- Appliance cutout opening not beaded for beaded Inset style cabinet.

**NOTE:** Appliance openings in frames will not have a beaded perimeter when ordered on beaded inset cabinetry. Designer must specify in writing if the appliance opening is to have a bead.

**BASE WARMING DRAWER CABINET**

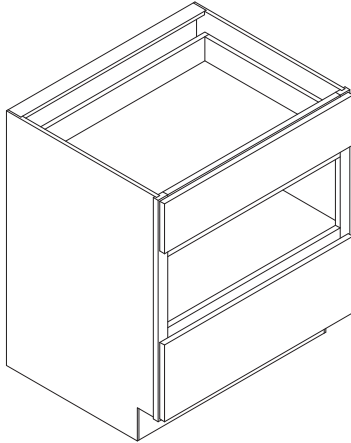

PRODUCT CODE	LEVEL 1	LEVEL 2
--------------	---------	---------

BWDC24		
--------	--	--

BWDC27		
--------	--	--

BWDC30		
--------	--	--

BWDC33		
--------	--	--

BWDC36		
--------	--	--

NOTE: BWDC cabinet cannot have decorative ends except for a standard finish end or standard flush finish when using maximum width cutout for the specific cabinet's overall width.

**BASE WARMING DRAWER CABINET**

- Warming drawer cabinet with functional drawer boxes above and below cutout.
- 2" center frame rails standard.
- Specify cutout width x height. Use of template page for BWDC is recommended.
- 1/2" floors above and below cutout.
- Cutout will be located so that the top drawer front aligns with adjacent top drawer fronts, as standard. Specify if another dimension is required.
- See template page for more details.
- Appliance openings in frames will not have a beaded perimeter when ordered on beaded inset cabinetry. Designer must specify in writing if the appliance opening is to have a bead.

**BASE COOKTOP CABINET, THREE DRAWER FRONTS**



BCC3D30
---------

BCC3D33
---------

BCC3D36
---------

BCC3D39
---------

BCC3D42
---------

**BASE COOKTOP CABINET WITH TWO DRAWERS**

- Top, false drawer front
- Two, 8" high lower drawer boxes
- Standard with 8 1/4" of clearance from top for Inset cabinets and 7 7/8" for all overlay style cabinets.

BASE COOKTOP CABINETS

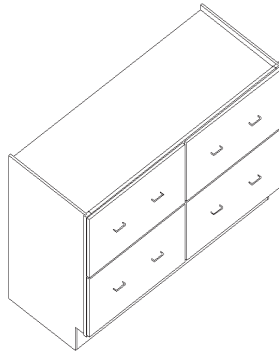
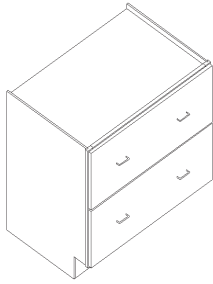

PRODUCT CODE	LEVEL 1	LEVEL 2
BCC2D30		
BCC2D36		
BCC4D48		
BCC4D60		

**BASE COOKTOP CABINET WITH DRAWERS**

- Standard base height of 34 1/2" high unless specified.
- Cabinet height may be specified at no extra charge, minimum height is 25".
- This cabinet will have a recessed top (like a Wall cabinet).
- BCC2D will have 2 equal spaced, 8" high drawer boxes.
- BCC4D will have 4 equal spaced, 8" high drawer boxes.
- If height is less than 27", drawer boxes will reduce accordingly and will remain equal sizes.

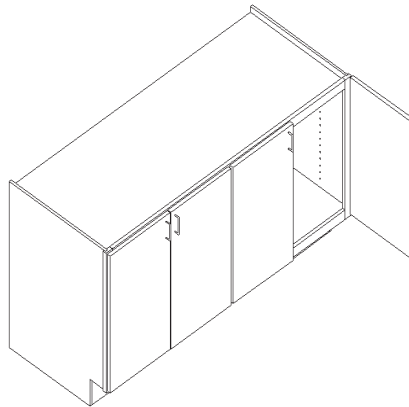
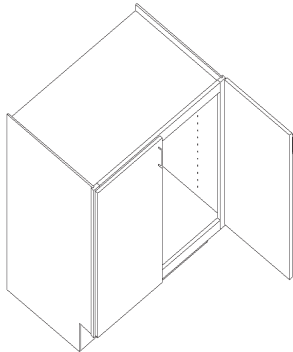

BCC-2-30
BCC-2-36
BCC-2-48
BCC-4-60

**BASE COOKTOP CABINET WITH DOORS**

- Standard base height of 34 1/2" high unless specified.
- Cabinet height may be specified at no extra charge, minimum height is 25".
- This cabinet will have a recessed top (like a Wall cabinet).
- Cabinets 39" wide or greater will have a fixed center stile as standard.
- Shelf quantity will be based on overall cabinet height. Minimum height for adjustable shelf is 25 1/2".

**BASE PENINSULA CABINETS**

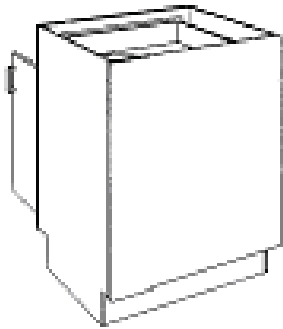

	PRODUCT CODE	LEVEL 1	LEVEL 2
24" deep	BPSC2724		
	BPSC2724FD		
24 1/2" deep	BPSC2724.5		
	BPSC2724.5FD		
24 3/4" deep	BPSC2724.75		
	BPSC2724.75FD		

**BASE PENINSULA STARTER CABINET**

- Toe space and a 1/2" finished panel is applied to "kitchen" side of cabinet
- Standard overall depth is 24". (Accommodates adjacent peninsula cabinet.)
- Optional depths of 24 1/2" and 24 3/4" are offered to accommodate 1/2" or 3/4" back panels adjacent to this cabinet.
- One 3/4" depth, adjustable shelf for cabinet with top drawer.
- Full height door (FD) cabinets will have two 3/4" depth, adjustable shelves

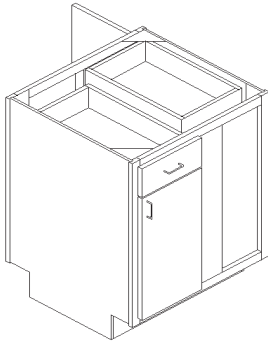

PBB36
PBB39
PBB42
PBB45
PBB48

**PENINSULA BASE BLIND CABINET**

- Specify blind side left (L) or right (R), right is (R) shown.
- Two doors on back, one door on front hinged to blind side. Blind side door will have 90° hinging when FOL-C or SOL-C
- One drawer opens to front; one drawer opens to back.
- One full depth adjustable shelf.
- Inside 1/4" panel covers blind opening.
- Cabinets 39" wide or greater will have a fixed center stile as standard on back side of cabinet.
- See Base Blind cabinet for specific blind corner cabinet details and limitations.
- Blind side typically requires a 3" filler to adjoining cabinets, provided with cabinet. (Field installation required.)

BLIND PENINSULA CABINET	DOOR OPENING (blind side)
PBB36	7 1/2"
PBB39	10 1/2"
PBB42	13 1/2"
PBB45	16 1/2"
PBB48	19 1/2"

**NOTE:** The adjacent cabinet at right angle to the Blind Base must have an extended stile or filler for proper door and drawer clearance. Hardware pulls will require additional clearance.

**BASE PENINSULA CABINETS**

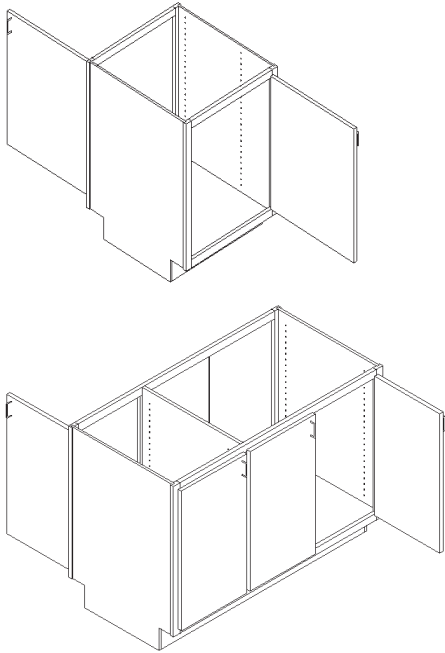

PRODUCT CODE	LEVEL 1	LEVEL 2
PBFD18		
PBFD21		
PBFD24		
PBFD24-4		
PBFD27		
PBFD30		
PBFD33		
PBFD36		
PBFD39		
PBFD42		
PBFD45		
PBFD48-6*		

**PENINSULA BASE, FULL HEIGHT DOOR(S)**

- Two full depth, adjustable shelves.
- Hinge side specified on single door cabinets will be same on front and back unless otherwise specified (right shown).
- Cabinets 39" wide or greater will have fixed center stile.
- \*PBFD48-6P will have partition behind the middle, offset stile with two adjustable, full depth shelves on either side.
- \*PBFD48-6 will have single door on the rear hinged opposite of front, single door. PBFD48-6L (left) shown.

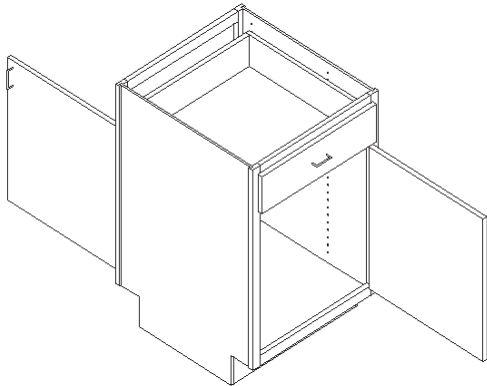

One door, one drawer front  
per side

PB18
PB21
PB1D24

**PENINSULA BASE, 1 DOOR, 1 DRAWER**

- One adjustable, full depth shelf
- Hinge side specified on single door cabinets will be same on front and back unless otherwise specified.
- Front of cabinet will have working drawer and the back of cabinet will be a false drawer unless otherwise specified.

**BASE PENINSULA CABINETS**

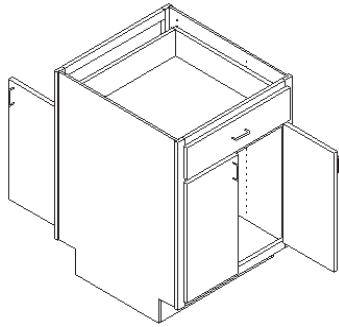

Two doors and one drawer front per side

PRODUCT CODE	LEVEL 1	LEVEL 2
--------------	---------	---------

PB1D24-2		
PB1D27		
PB1D30		
PB1D33		
PB1D36		
PB1D39		
PB1D42		
PB1D45		

**PENINSULA BASE, 1 DRAWER**

- Front of cabinet will have one working drawer and the back of cabinet will be a false drawer front unless otherwise specified.
- One adjustable, full depth shelf.
- Cabinets 39" wide or greater will have a fixed center stile as standard.

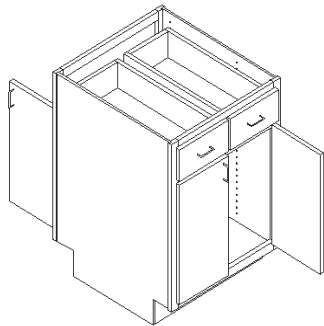

Two doors and two drawer fronts per side

PB27		
PB30		
PB33		
PB36		
PB39		
PB42		
PB45		

**PENINSULA BASE, 2 DRAWERS**

- Front of cabinet will have two working drawers and the back of cabinet will be two false drawer fronts unless otherwise specified.
- One adjustable, full depth shelf.
- Cabinets 39" wide or greater will have a fixed center stile as standard.

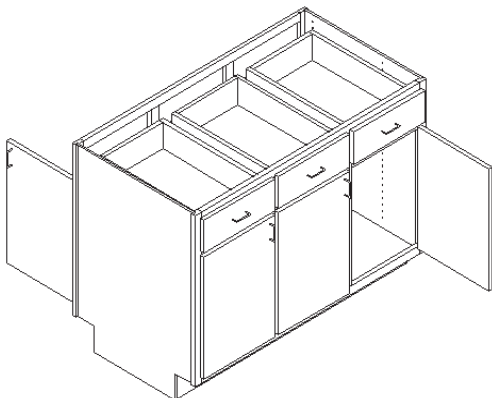

Three doors and three drawer fronts per side

PB39-6		
PB42-6		
PB45-6		
PB48-6		
PB51-6		
PB54-6		

**PENINSULA BASE, 6 DOORS**

- Hinge side specified for single door opening (left shown) with opposite side hinging on back of cabinet.
- Front of cabinet will have three working drawers and the back of cabinet will be false drawer fronts unless otherwise specified.
- Partition behind the middle, offset stile with one adjustable, full depth shelf on either side.

BASE RADIUS PENINSULA CABINET

PRODUCT LEVEL 1 LEVEL 2  
CODE

BRPC24

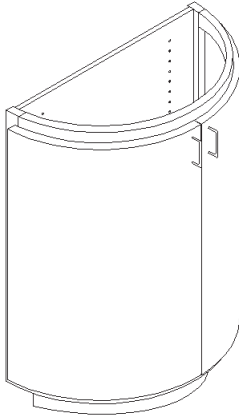

**Please send for a Custom quote if any of the following apply:**

- Cabinet height is modified above 42"
- Cabinet width or depth is changed
- Another cabinet configuration is wanted
- MDF door style is chosen (Summit MDF not available)
- See general accessories for radius molding offerings

- 24" wide, 12" deep standard
- Two adjustable shelves
- Cabinet has vertical center stile.
- Radius cabinets may ship separately from the rest of the order. Extended lead times may apply.
- The following door styles are not available: Cafe, Craftsman, Cottage, Lakeland, LaPorte, Lincoln, Madrid, Newport, Prairie, Sardinia, Valletta, Verona, Woodridge, or Zenith
- Furniture ends not available.



**BASE ANGLED INSIDE CORNER**

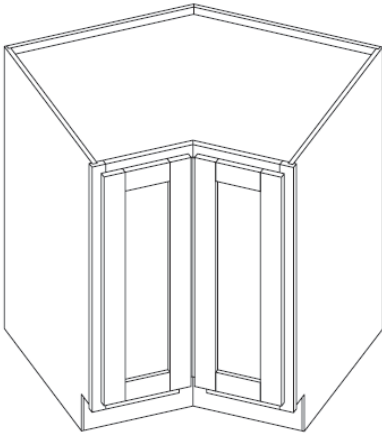

PRODUCT CODE	LEVEL 1	LEVEL 2
BAIC11		
BAIC14		
BAIC17		

BAIC11

BAIC14

BAIC17

Product Code	Face frame width	Back width / wall space
BAIC11	11	21
BAIC14	14	24
BAIC17	17	27

**BASE 135 DEGREE ANGLED CORNER CABINETS**

- 34 1/2" high standard
- 24" deep standard
- 135 degree inside (BAIC) or outside (BAOC) angled front with full height doors hinged to the outside.
- Two full depth adjustable shelves.
- Modifications to width or depth will require a custom quote.

**BASE ANGLED OUTSIDE CORNER**

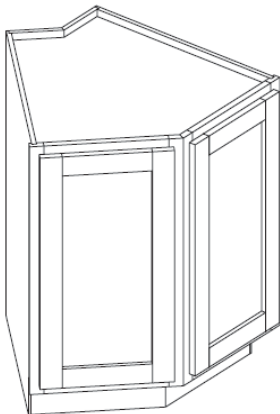

BAOC16

BAOC19

BAOC22

Product Code	Face frame width	Back width / wall space
BAOC16	16	6
BAOC19	19	9
BAOC22	22	12

BASE ANGLED FRONT CABINET

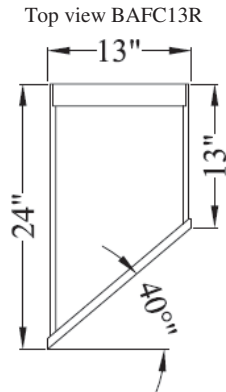
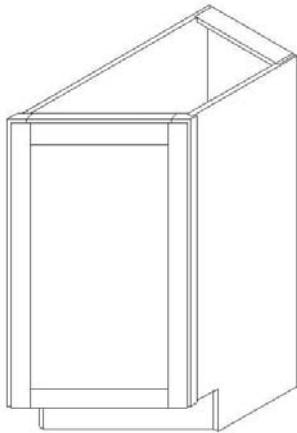

PRODUCT CODE	LEVEL 1	LEVEL 2
--------------	---------	---------

BAFC13L		
---------	--	--

BAFC13R		
---------	--	--

- 13" wide, 34 1/2" high standard
- Short side = 13" deep, long side = 24" deep
- Angled front with full height door.
- Specify left (L) or right (R) to indicate end of cabinet run for deeper cabinet side.
- Hinging will be to the shallower side (right (R) illustrated). If opposite hinging is required please specify on order.
- Two full depth adjustable shelves.
- 40 degree angled front.
- For a 45 degree angle on the front, the width of the cabinet will need to be 11" wide with 13" depth for the shallow side. Or, the depth of the shallow side will need to be 11" keeping the width at 13".

**BASE RADIUS END ENTRY CABINETS**

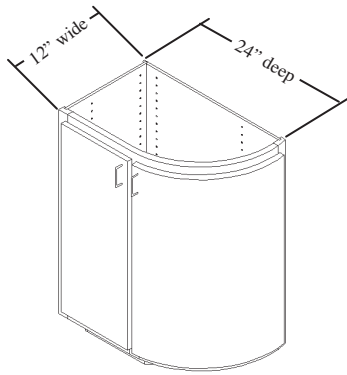

**Please send for a Custom quote if any of the following apply:**

- Cabinet height is modified above 42"
- Cabinet width or depth is changed
- Another cabinet configuration is wanted
- MDF door style is chosen (Summit MDF not available)
- See general accessories for radius molding offerings

PRODUCT CODE	LEVEL 1	LEVEL 2
BREE12R		
BREE12L		

**BASE RADIUS END ENTRY, 12" WIDE AND 24" DEEP**

- 12" wide, 24" deep standard
- Specify (L) left or (R) right for end of run (left pictured).
- Two doors, one radius and one flat
- Two adjustable shelves
- Frame has vertical center stile.
- Radius cabinets may ship separately from the rest of the order. Extended lead times may apply.
- See general accessories for radius molding offerings.
- The following door styles are not available: Cafe, Craftsman, Cottage, Lakeland, LaPorte, Lincoln, Madrid, Newport, Prairie, Sardinia, Valletta, Verona, Woodridge or Zenith
- Furniture ends not available.

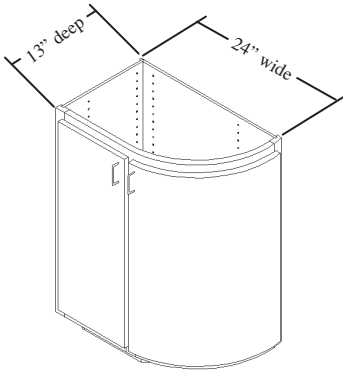

**Please send for a Custom quote if any of the following apply:**

- Cabinet height is modified above 42"
- Cabinet width or depth is changed
- Another cabinet configuration is wanted
- MDF door style is chosen (Summit MDF not available)
- See general accessories for radius molding offerings

BREE24R
BREE24L

**BASE RADIUS END ENTRY, 24" WIDE AND 13" DEEP**

- 24" wide, 13" deep standard
- Specify (L) left or (R) right for end of run (right pictured).
- Two adjustable shelves
- Frame has vertical center stile.
- Radius cabinets may ship separately from the rest of the order. Extended lead times may apply.
- See general accessories for radius molding offerings.
- The following door styles are not available: Cafe, Craftsman, Cottage, Lakeland, LaPorte, Lincoln, Madrid, Newport, Prairie, Sardinia, Valletta, Verona, Woodridge or Zenith
- Furniture ends not available.

**BASE ANGLED CABINETS**

PRODUCT LEVEL 1 LEVEL 2  
CODE

**BAC-1-1313**

- BAC-1 is 13" x 13" with 45 degree front.
- 1 door, specify left (L) or right (R) hinge
- 2 full depth adjustable shelves.

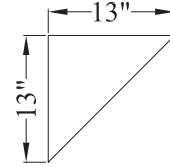
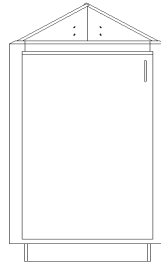

BAC-1-1313

**BAC-1 2424**

**BAC-1-2424**

- BAC-1 is 24" x 24" with 45 degree front.
- 2 doors, no center style.
- 2 full depth adjustable shelves.

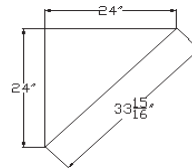
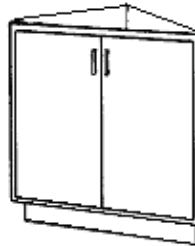

BAC-1-2424

**BAC-2-1313**

**BAC-2 1313**

- BAC-2 is 13" x 13" with two 67.5 degree fronts.
- 2 full depth adjustable shelves.

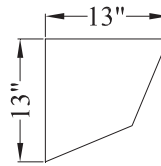
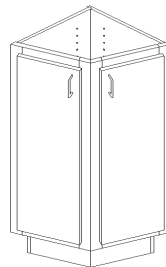

BAC-2-1313

**BAC-2 2424**

**BAC-2 2424**

- BAC-2 is 24" x 24" with two 67.5 degree fronts.
- 2 full depth adjustable shelves

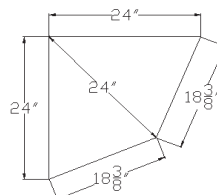
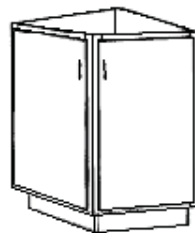

BAC-2-2424

**BASE ANGLE CABINET**

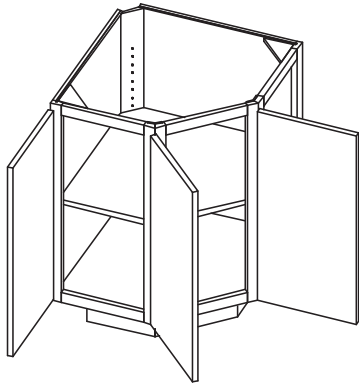

Adjustable Shelf

- 24” wide, 24” deep standard
- BACA’s have two adjustable shelves (not illustrated).
- Specify hinge side (all three doors will open from the same side)

PRODUCT LEVEL1 LEVEL2  
CODE

BACA-3

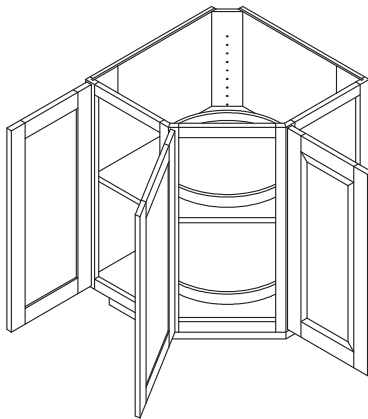

Revolving Shelf

- 24” wide, 24” deep standard
- BACR’s have 2 adjustable shelves and 3 turn tables (not illustrated).
- Specify hinge side (all three doors will open from the same side)

BACR-3

**BASE RADIUS CABINET**

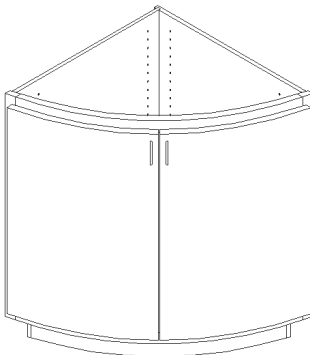

- 24” deep standard
- Specify (L) left or (R) right for end of run.
- 2 adjustable shelves
- Frame has vertical center stile
- Radius cabinets may ship separately from the rest of the order. Extended lead times may apply.
- The following door styles are not available: Cafe, Craftsman, Cottage, Lakeland, LaPorte, Lincoln, Madrid, Newport, Prairie, Sardinia, Valletta, Verona, Woodridge or Zenith

BRC2424

**Please send for a Custom quote if any of the following apply:**

- Cabinet height is modified above 42”
- Cabinet width or depth is changed
- Another cabinet configuration is wanted
- MDF door style is chosen (Summit MDF not available)
- See general accessories for radius molding offerings

**BASE IRONING BOARD CABINET**

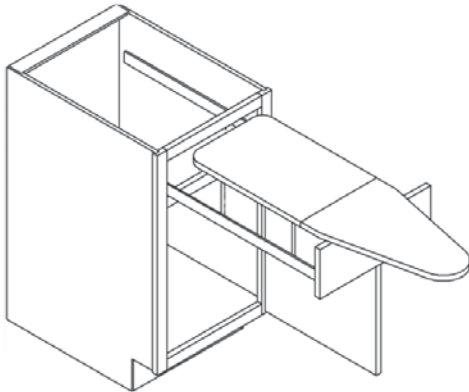

PRODUCT CODE	LEVEL 1	LEVEL 2
BIRON18		
BIRON21		

- 24” deep standard
- Folding ironing board replaces top drawer box.
- Slab drawer front only available.
- Easy to use: open until gravity lock engages and unfold board.
- 24” deep cabinet: ironing surface will be approximately 12” W x 37 1/2” L.
- 18” and 21” deep cabinet: ironing surface will be approximately 12” W x 29 1/4” L.
- Minimum cabinet width = 18” (15” frame opening)
- One adjustable 4” rollout shelf in lower opening, standard. (Not illustrated)
- Includes a heat reflecting cover for the ironing board. (Replacement covers available, contact Customer Service)
- Specify hinge side for door.

**BASE COMBINATION DOUBLE DRAWER CABINET**

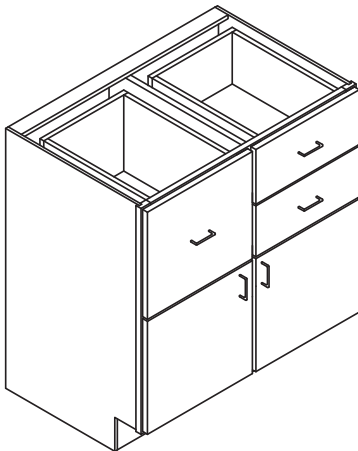

BCD30
BCD33
BCD36

- Specify left (L) or right (R) for the side with two drawers (right shown).
- Two 4” drawers, and one 10” drawer, with two doors below.
- Includes clear sliding bread box lid in larger drawer.
- No shelf in bottom section.

**BASE CANNED FOOD STORAGE CABINETS**

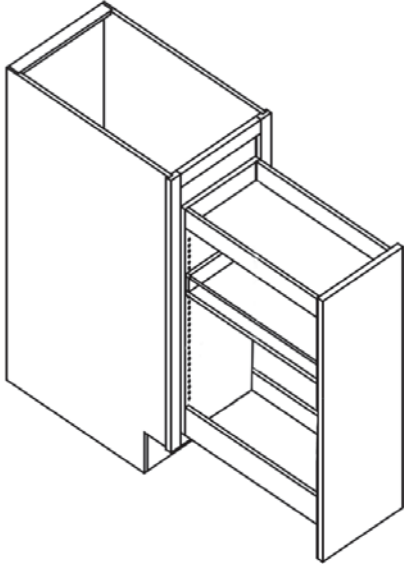

PRODUCT CODE	LEVEL 1	LEVEL 2
BCGS624		
BCGS924		
BCGS1224		
BCGS1524		
BCGS1824		
BCGS2124		

**BASE CAN GOOD STORAGE CABINET**

- Pullout canned good storage rack with adjustable shelves
- One shelf for standard 34 1/2” height cabinets.
- Minimum width of 6”

NOTE: Base Canned Good Storage Units under 8” wide are not recommended to store cans. The shelf would only be wide enough for spices or other smaller items.

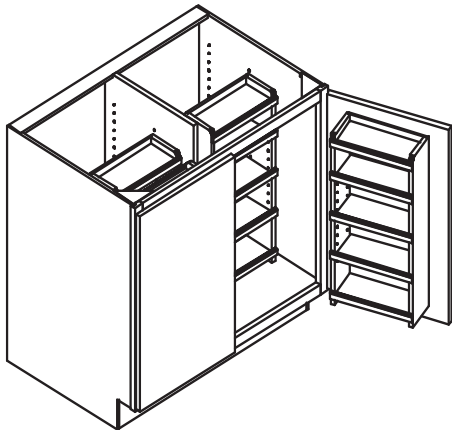

BMFS36
--------

**BASE MULTI FOOD STORAGE CABINET**

- Two interior swing outs with adjustable shelves.
- Storage rack on each door with adjustable shelving.
- Two shallow, adjustable shelves on each side of centered partition, located behind swing outs.
- Doors must be able to open a minimum of 105° to allow access to the storage space in the rear.
- Reducing the cabinet width is not recommended as this will limit the access space to the rear storage area.

BASE WICKER VEGETABLE BASKET CABINETS

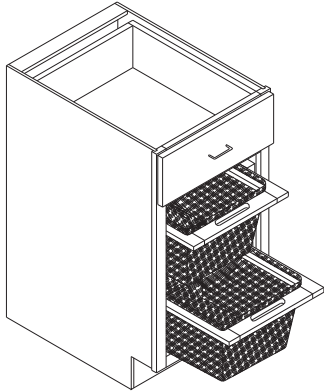

PRODUCT CODE	LEVEL 1	LEVEL 2
B1DVB15		
B1DVB18		

**BASE WICKER VEGETABLE BASKET CABINET**

- Two wicker vegetable baskets on wood slides. Except when used as **Inset cabinet**, only one wicker basket available.
- Standard top 4” high drawer box.
- Finished interior standard.
- Please contact Customer Service for availability prior to modifying any dimension.

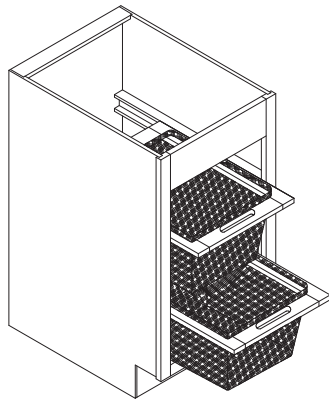

PRODUCT CODE	LIST PRICE
BVB15	
BVB18	

**BASE WICKER VEGETABLE BASKET CABINET (no top drawer)**

- 5” straight valance top rail standard. Specify valance style if other design is desired.
- Two wicker vegetable baskets on wood slides.
- Finished interior standard.
- Please contact Customer Service for availability prior to modifying any dimension.



BASE APOTHECARY DRAWERS

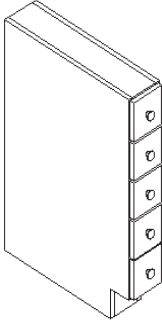

	PRODUCT CODE	LIST PRICE
13" deep	BAD613	
24" deep	BAD624	

- Two standard depths available, 24" deep illustrated.
- 5-piece drawer fronts are not available.
- 6" wide with five drawers.
- Knobs are for illustrative purposes only and must be purchased separately.

BASE WICKER SPICE DRAWER CABINET

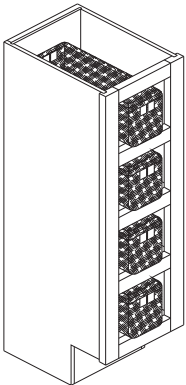

BWSD9

- 13" deep standard
- Four wicker spice baskets sit loose on fixed shelves.
- Finished interior.

**BASE WINE RACKS**

**ALL WINE RACKS ON THIS PAGE WILL BE THE SAME INTERIOR WOOD SPECIE AND FINISH AS EXTERIOR**

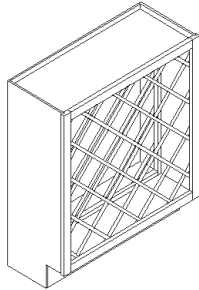

**BASE WINE LATTICE (BWL)**

- 13" deep standard
- 11/16" X 11/16" wood lattice
- 4" bottle ports
- Interior finished in matching job species /stain

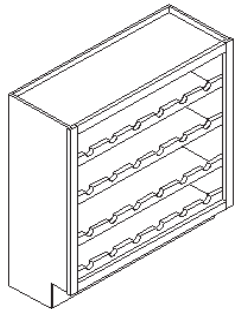

**BASE WINE BOTTLE SHELF (BWBS)**

- 13" deep standard
- 4 1/2" centers on rail holders
- Three adjustable bottle shelves
- Interior finished in matching job species /stain

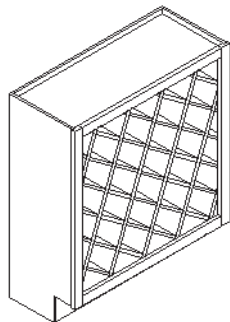

**BASE WINE SOLID LATTICE (BWSL)**

- 13" deep standard
- 1/2" edge banded plywood, full depth
- 4" bottle ports
- Interior finished in matching job species /stain

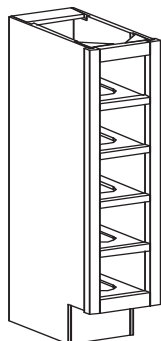

**BASE WINE CUBBY VERTICAL (BWCV)**

- 13" deep standard
- 1/2" plywood, framed construction
- Floors scooped so bottles do not roll
- Interior finished in matching job species /stain.
- Standard construction for units with multiple vertical columns will not have vertical dividers between them.
- BWCV6 illustrated

PRODUCT CODE	LIST PRICE
--------------	------------

BWL12
BWL15
BWL18
BWL21
BWL24
BWL27
BWL30

BWBS12
BWBS15
BWBS18
BWBS21
BWBS24
BWBS27
BWBS30

BWSL12
BWSL15
BWSL18
BWSL21
BWSL24
BWSL27
BWSL30

Bottle Quantity
BWCV6
BWCV12
BWCV18

BASE WINE RACKS, 40 1/2" HIGH

ALL WINE RACKS ON THIS PAGE WILL BE THE SAME  
INTERIOR WOOD SPECIE AND FINISH AS EXTERIOR

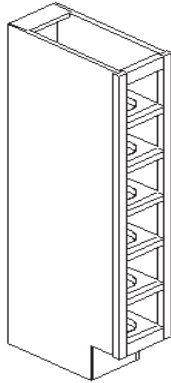

PRODUCT CODE	(Bottle Quantity)	LIST PRICE
BWCV640.5	6	
BWCV1240.5	12	
BWCV1840.5	18	

**BASE WINE CUBBY VERTICAL (BWCV), 40 1/2" HIGH**

- 13" deep standard, 40 1/2" high
- 1/2" plywood, framed construction
- Floors scooped so bottles do not roll
- Interior finished in matching job species /stain.
- Standard construction for units with multiple vertical columns will not have vertical dividers between them.
- BWCV640.5 illustrated



# NOTES

**FREE STANDING ISLAND**

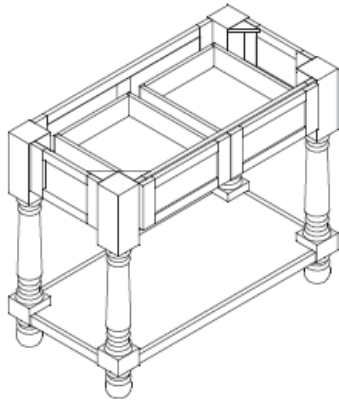

PRODUCT LEVEL1 LEVEL2  
CODE

FI42

**FREE STANDING ISLAND WITHOUT TOP**

- Overall width of island will be 42”.
- Overall height will be 34 1/2” .
- Overall depth will be 21” .
- Wainscot panels left, right, and rear.
- 4”x4” corner post, BC018 style

**ISLAND END PANELS**



Top View



Top View

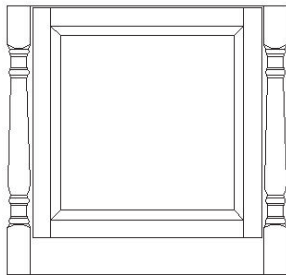

IEPFD  
Island End Panel with False Door

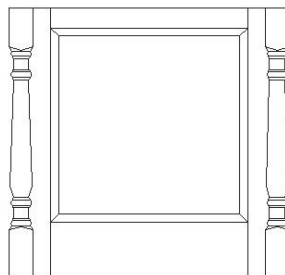

IEPWP  
Island End Panel with Wainscot Panel

IEPFD

\*+\$/ each additional door

IEPWP

\*+\$/ each additional panel

- One piece assembly for end-of-run, base application.
- Specify total width and height. Priced by overall square footage.
- Maximum width 51”
- 3” x 3” turned posts standard. Any other size post must be quoted.
- Specify post design; see ATPST in General Accessory section. This assembly will not work with post designs BC007, BC010, BC011, BC017, BC018 or BC020.
- Wainscot panel style (IEPWP) for mortise and tenon door designs only.
- Doors (panels for wainscot style) split into multiples at 24” intervals unless otherwise specified.
- \*Add \$ to square foot price for additional door or center panel. (Example: A 7 square foot IEPFD, with LEVEL1 doors, divided to have 2 doors / center panels total, would be \$ (7 sq. ft) plus \$ (1-additional center panel charge) = \$ List.
- LEVEL2 plus will be added per each door / center panel. (Example: Saxony door style at LEVEL2 + \$ would have \$ added for each door / center panel)

**PLANNING DESK**



Note: To align with standard base cabinet, drawer cabinet must be 7" high. To align with standard mini base cabinet, drawer cabinet must be 6" high.

- Standard height is 5 1/2" overall (1 1/2" top rail; no bottom rail).
- Specify height if aligning with other cabinets. (Add increase height modification from base section.)
- To accommodate most 5 piece drawer fronts a minimum height of 6" is required for full overlay drawer front. A minimum of 7" is required for semi overlay drawer fronts, with some exceptions (see specific door styles).

ONE  
DRAWER

PRODUCT CODE	LEVEL 1	LEVEL 2
PD1D2421		
PD1D2721		
PD1D3021		
PD1D3321		
PD1D3621		
PD1D2424		
PD1D2724		
PD1D3024		
PD1D3324		
PD1D3624		

TWO  
DRAWER

PD2D3321
PD2D3621
PD2D3324
PD2D3624

**PLANNING DESK MINI**

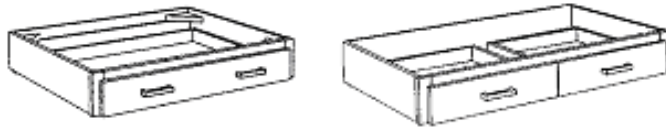

- Standard height is 4 5/8" overall (1 1/4" top rail; no bottom rail.)
- Specify height if aligning with other cabinets. (Add increase height modification from base section.)
- 2" high drawer box standard.
- Cannot be reduced in height.
- Slab drawer fronts are the only drawer fronts available.

ONE  
DRAWER

PDM1D2421
PDM1D2721
PDM1D3021
PDM1D3321
PDM1D3621
PDM1D2424
PDM1D2724
PDM1D3024
PDM1D3324
PDM1D3624

TWO  
DRAWER

PDM2D3321
PDM2D3621
PDM2D3324
PDM2D3624

**PLANNING DESK LEGS**



STYLE A



STYLE B

- Standard is 34 1/2" high, 21" or 24" deep.
- Finished on both sides and face edge.
- Front flat will equal height of Planning Desk.

PDLA21
PDLA24
PDLB21
PDLB24

**SLIDE OUT KEYPAD DRAWERS**

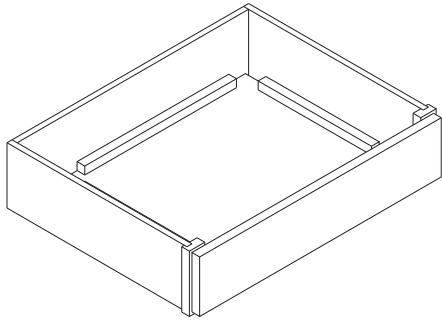

	PRODUCT CODE	LEVEL1	LEVEL2
21 " deep	KPD2421		
	KPD2721		
	KPD3021		
	KPD3321		
24" deep	KPD2424		
	KPD2724		
	KPD3024		
	KPD3324		

**KEYPAD DRAWER**

- Slide out keypad platform
- Single drawer only with fold down drawer front.
- Back and side fence rails attached to top of platform.
- Standard height is 5 1/2" overall. (4" high opening with a 1 1/2" bottom rail; no top rail)
- Specify height if aligning with other cabinets. (Add increase height modification from base section)
- To accommodate most 5 piece drawer fronts a minimum height of 6" is required for full overlay drawer front. A minimum of 7" is required for semi overlay drawer fronts. (See specific door styles for exceptions.)

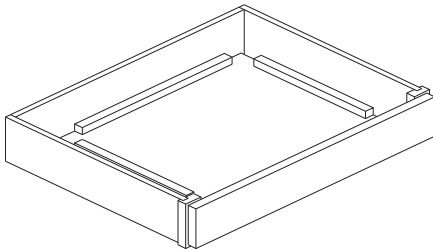

21 " DEEP	KPDM2421		
	KPDM2721		
	KPDM3021		
	KPDM3321		
24" DEEP	KPDM2424		
	KPDM2724		
	KPDM3024		
	KPDM3324		

**MINI KEYPAD DRAWER**

- Slide out keypad platform
- Single drawer only with fold down drawer front.
- Back and side fence rails attached to top of platform.
- Standard height is 4 5/8" overall. (1 1/4" bottom rail; no top rail)
- Specify height if aligning with other cabinets. (Add increase height modification from base section)
- Cannot be reduced in height.
- Slab drawer front only available.

**BASE SHELVES**

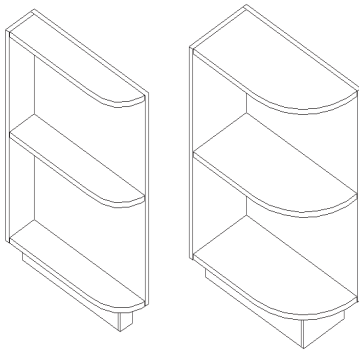

PRODUCT CODE	LIST
BES6	L/R
BES12	L/R

**BASE END SHELF**

- Specify left [L] or right [R] end of cabinet run. (left shown)
- Standard widths of 6” and 12”
- Standard depth of 24”
- Standard height of 34 1/2”
- 3” radius on shelves
- Finished to match job specie/stain
- Back sides not finished.
- Use flush finished end modification, MWFFE, for exposed side.

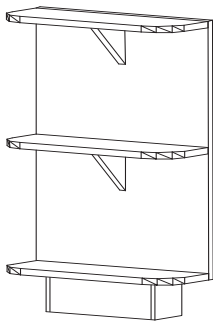

BPS12
-------

**BASE PENINSULA SHELF**

- Standard width of 12”
- Standard depth of 24”
- Standard height of 34 1/2”
- 3” radius on shelves
- Finished to match job specie/stain
- Back sides not finished.
- Use flush finished end modification, MWFFE, for exposed ‘back’.



**BASE FILLERS**

**BASE FILLER**

- 3/4" solid wood frame stock
- Standard widths of 3" and 6"
- Standard ships finished on face and all four 3/4" edges
- Fillers are shipped at the size indicated in the product nomenclature and are not cut down at the factory except by special request only.



Fillers are shipped at the size indicated in the product nomenclature and are not cut down at the factory except by special request only.



PRODUCT CODE	LIST PRICE
BF330	
BF334.5	
BF336	
BF340.5	
BF630	
BF634.5	
BF636	
BF640.5	

**BASE OVERLAY FILLER STRIP**

- Overlay only, does not include filler
- All four edges will be profiled to match door edges.
- Length will match height of door/drawer overlay.
- Finished on face and all four 3/4" edges.
- Madrid, Sardinia, and Valletta overlays cannot be any smaller than 2 7/8" wide.
- When adding flutes:  
 2 flutes are standard on BOFS3 (2 3/4" wide)  
 5 flutes are standard on BOFS6 (5 3/4" wide)



(2 3/4" W)

BOFS3
-------

(5 3/4" W)

BOFS6
-------

**BASE CORNER FILLER**

- 90 degree angle
- BCF330 spans 3" for each leg. BCF630 spans 6" for each leg.
- Finished on face and 3/4" edges
- Fillers are shipped at the size indicated in the product nomenclature and are not cut down at the factory except by special request only.



Fillers are shipped at the size indicated in the product nomenclature and are not cut down at the factory except by special request only.



BCF330
BCF334.5
BCF336
BCF340.5
BCF630
BCF634.5
BCF636
BCF640.5

## BASE FILLERS

### BASE FILLER WITH RETURN

- 3" wide or 6" wide solid wood face frame with 3/4" plywood return.
- Available at 34 1/2" and 40 1/2" high
- 24" deep
- Specify L or R side for return (left shown).
- Return panel is finished on both sides.
- Add modification charge for flush finished end.
- Add modification charge for flush toe kick to create an end panel for dishwasher or other appliance.

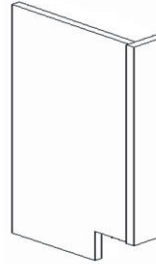

PRODUCT CODE	LIST PRICE
BFR334.5	
BFR340.5	
BFR634.5	
BFR640.5	



Fillers with returns are shipped at the size indicated in the product nomenclature and are not cut down at the factory except by special request only.

### BASE FILLER WITH RETURN, BOTH SIDES

- 3" wide or 6" wide solid wood face frame with two 3/4" plywood returns.
- Available at 34 1/2" and 40 1/2" high
- 24" deep
- Finished ends on both returns are standard.
- Add modification charge for flush finished ends.

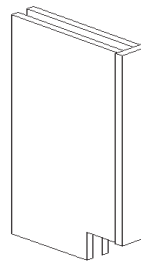

BFRB334.5
BFRB340.5
BFRB634.5
BFRB640.5



Fillers with returns are shipped at the size indicated in the product nomenclature and are not cut down at the factory except by special request only.

### DISHWASHER END PANEL

- 34 1/2" high, 24" deep standard
- 3/4" x 3" solid wood face frame with 3/4" plywood return.
- No toe space cutout
- Finished return panel for SRDWEP (standard 1/4" side reveal)
- Flush finished return panel for FFDWEP (flush finish)



Standard 1/4" reveal
SRDWEP
Flush finish end
FFDWEP



Fillers with returns are shipped at the size indicated in the product nomenclature and are not cut down at the factory except by special request only.

### BASE FILLER SPICE PULLOUT

- 30" high wood pullout for 24" deep application. Dimensions cannot be modified.
- Available in 3" or 6" wide
- Toe kick not included.
- Organizer installs between two adjacent cabinets. (see illustration)
- 150# full extension glides
- 3 adjustable wood shelves with natural finish and chrome side rails.
- Ships with loose 29 7/8" high filler. If flush toe look is desired, must add MFTK (flush toe modification).
- **\*\*Ships with loose overlay filler, sized to match job specific overlay. Inset and SOLK lipped orders will ship with filler only, no overlay included.**

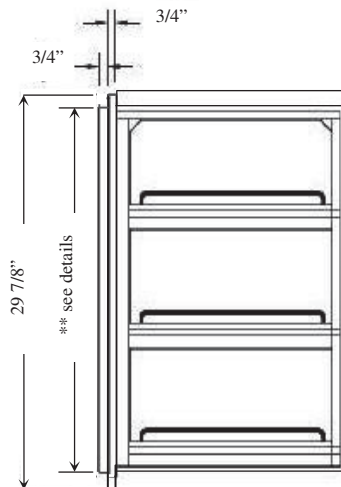

3" wide
BFSP3
6" wide
BFSP6

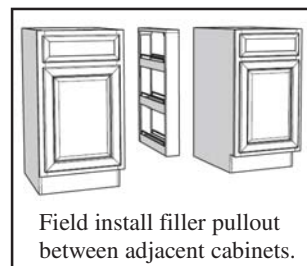

**BASE FILLERS**

**ANGLED FILLER**

- 3/4" solid wood filler
- Edges cut for 45 degree installation
- Occupies 3" width of cabinet run
- Fillers are shipped at the size indicated in the product nomenclature and are not cut down at the factory except by special request only.



Fillers are shipped at the size indicated in the product nomenclature and are not cut down at the factory except by special request only.



PRODUCT CODE	SPECIFY	LIST
BAF30	L/R	
BAF34.5	L/R	
BAF36	L/R	
BAF40.5	L/R	

**ANGLED FILLER WITH RETURN**

- 3/4" plywood return
- 45 degree angle
- Occupies 3" of cabinet run
- Specify left [L] or right [R] end of cabinet run.
- Overall depth is 24", return depth is 21"
- Finished side is standard on return
- Add modification charge for flush finished end.



Fillers with returns are shipped at the size indicated in the product nomenclature and are not cut down at the factory except by special request only.

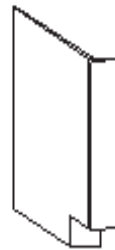

(left shown)

BAFR34.5	L/R	
BAFR40.5	L/R	

**135 DEGREE ANGLE FILLER ONLY (not pictured)**

- Two 3/4" solid wood frame stock joined to form a 135° angle.
- 2" wide face of each "wing".
- Edges are square with face of each section.
- Standard ships finished on face of inside angle and all 3/4" edges.
- See top view sketch for amount of run space covered.



Fillers are shipped at the size indicated in the product nomenclature and are not cut down at the factory except by special request only.

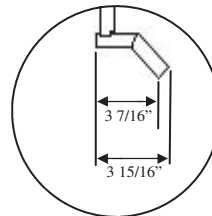

Top View

FILLER ONLY	
B2AF30	
B2AF34.5	
B2AF36	
B2AF40.5	

**135 DEGREE ANGLE FILLER WITH RETURN**

- Two 3/4" solid wood frame stock joined to form a 135° angle with return.
- 2" wide face of each "wing".
- Return side depth is 24".
- Edges are square with face of each section.
- Specify (L) left or (R) right side for return. (Left shown)
- Finished face of inside angle is standard.
- Finished side is standard on return.
- Add modification charge for flush finished end.
- See top view sketch for amount of run space covered.



Fillers with returns are shipped at the size indicated in the product nomenclature and are not cut down at the factory except by special request only.

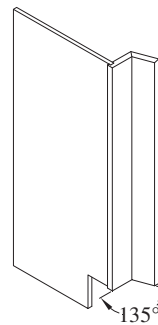

FILLER WITH RETURN	
B2AFR34.5	L/R
B2AFR40.5	L/R

VALANCE TOE FILLERS

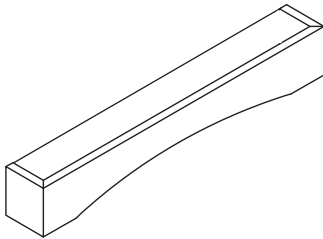

**ARCHED VALANCE TOE FILLER**

- 4 1/2" high
- 4" deep
- Valance toe fillers are made 1" wider than overall cabinet width, fits into toe space (see illustration below).
- Shipped loose

PRODUCT CODE	LIST PRICE
AVTF25	
AVTF28	
AVTF31	
AVTF34	
AVTF37	
AVTF40	
AVTF43	
AVTF46	
AVTF49	

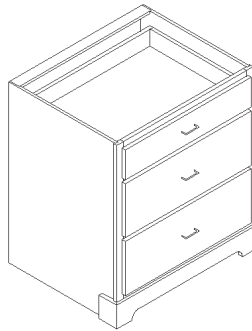
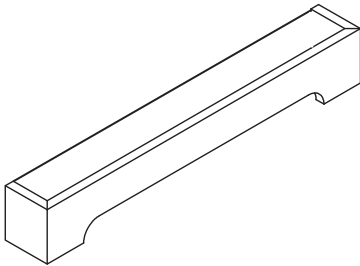

**FURNITURE VALANCE TOE FILLER**

- 4 1/2" high
- 4" deep
- Valance toe fillers are made 1" wider than overall cabinet width, fits into toe space (see illustration).
- Shipped loose

FVTF25	
FVTF28	
FVTF31	
FVTF34	
FVTF37	
FVTF40	
FVTF43	
FVTF46	
FVTF49	

**FURNITURE PLATFORMS**

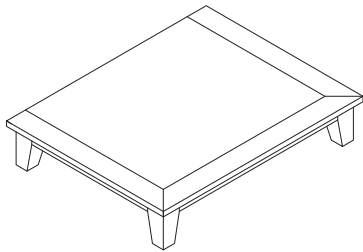

**TAPER FEET FURNITURE PLATFORM**

- 6 3/4" overall height. (The platform is 2 1/4" taller than the standard toe space. To align with adjacent cabinets, the base cabinet used in conjunction with the platform will need the height reduced by 2 1/4". This height adjustment will not be made by the factory unless specified on the order.)
- The sizes shown are to match the corresponding cabinet sizes.
- If FOL and SOL, the platform will have a finished size of 1 1/2" deeper and 1 1/2" wider than listed. (Example: TAFP2421 will have overall dimensions of 25 1/2" wide by 22 1/2" deep.) If Inset, the platform will have a finished size of 3/4" deeper and 1 1/2" wider than listed. (Example: TAFP2421 will have overall dimensions of 25 1/2" wide by 21 3/4" deep.)
- Designed to be used with a base cabinet having NOTK (omit toe kick modification) applied.
- 3/4" plywood top with 3" wide solid wood edge on front and both sides. Machine edge profile as standard.
- 2" straight valances between the feet on front and both sides.

PRODUCT CODE	LIST PRICE
TAFP2424	
TAFP2724	
TAFP3024	
TAFP3324	
TAFP3624	
TAFP3924	
TAFP4224	
TAFP4524	
TAFP4824	
TAFP5124	
TAFP5424	
TAFP5724	
TAFP6024	

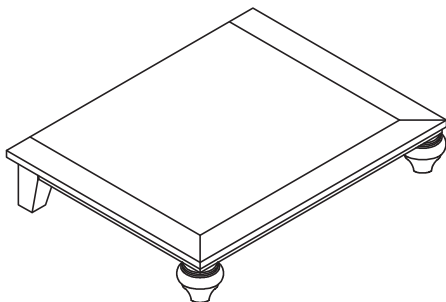

**COUNTRY FRENCH FURNITURE PLATFORM**

- 6 3/4" overall height. (The platform is 2 1/4" taller than the standard toe space. To align with adjacent cabinets, the base cabinet used in conjunction with the platform will need the height reduced by 2 1/4". This height adjustment will not be made by the factory unless specified on the order. )
- The sizes shown are to match the corresponding cabinet sizes.
- If FOL and SOL, the platform will have a finished size of 1 1/2" deeper and 1 1/2" wider than listed. (Example: CFFP2421 will have overall dimensions of 25 1/2" wide by 22 1/2" deep.) If Inset, the platform will have a finished size of 3/4" deeper and 1 1/2" wider than listed. (Example: CFFP2421 will have overall dimensions of 25 1/2" wide by 21 3/4" deep.)
- Designed to be used with a base cabinet having NOTK (omit toe kick modification) applied.
- 3/4" plywood top with 3" wide solid wood edge on front and both sides. PRS-2 edge profile as standard.
- 2" arched valances between the feet on front and both sides.

CFFP2424
CFFP2724
CFFP3024
CFFP3324
CFFP3624
CFFP3924
CFFP4224
CFFP4524
CFFP4824
CFFP5124
CFFP5424
CFFP5724
CFFP6024

**BASE ACCESSORIES**

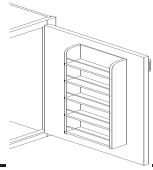
	PRODUCT CODE	LIST
<p><b>SPICE RACK ON DOOR</b></p> <p>3 1/2" deep, wood rack with fixed shelves mounted on cabinet door.            Not available on cabinets less than 9" wide.            Spice shelf accessory interior depth is 2 1/2".            Height of each shelf section varies from approximately 5" to 7" depending on the height of the cabinet frame opening.</p>	ASROD	
<p><b>BASE CAN RACK (ATTACHED TO DOOR)</b></p> <p>Pullout wood storage rack with adjustable shelves</p>	ABCR	
<p><b>SINGLE WASTE BASKET ( ATTACHED TO DOOR)</b></p> <p>15" minimum cabinet width (12" wide minimum cabinet opening). Specify 'W' for white cans or 'P' for pewter cans. Pewter is not available for all inset cabinet configurations.            Specific waste basket capacity varies based on cabinet details.</p>	AWBAS-W AWBAS-P	
<p><b>DOUBLE WASTE BASKET (ATTACHED TO DOOR)</b></p> <p>18" minimum cabinet width (15" wide minimum cabinet opening). Specify 'W' for white cans or 'P' for pewter cans. Pewter is not available for all inset cabinet configurations.            Specific waste basket capacity varies based on cabinet details.</p>	AWBAD-W AWBAD-P	
<p><b>FLIPPER (POCKET)DOOR GLIDES</b></p> <p>Installed mechanism for stowing door inside cabinet as in entertainment cabinets. Minimum cabinet depth is 13 1/2" to allow for hardware.            Add to cabinet price; priced per set of doors.            Adding flipper doors to a cabinet will cancel all adjustable shelves in that section. When needing adjustable shelves, a loose shelf accessory will need to be added to cabinet price for each adjustable shelf.            When needing finished interior, the matching wood interior modification will need to be added to cabinet price.            When adding flipper doors to cabinet, interior opening width will be 8" less than the overall cabinet width if FOL-C. If SOL or Inset, the interior opening width will be 9 1/4" less than the overall cabinet width. Example: 30" wide, FOL-C cabinet will have an interior opening size of 22" wide.            Doors larger than 26" wide or 72" tall require large flipper door glides (ALFDG).</p>	AFDG ALFDG	
<p><b>CUTTING BOARD BEHIND DRAWER</b></p> <p>1 1/2" Pretreated hard rock maple cutting boards for cabinets up to 27" wide with single top drawer.            Includes scooped drawer box sides and full extension undermount glides as standard.            Cutting board will have feet attached to keep it in place while in cabinet drawer.            May be used in the drawer or on the counter top.            A bottle of Mystery Oil for retreating the cutting board will be included.</p>	ACB-BD	
<p><b>CUTTING BOARD OVER DRAWER</b></p> <p>1 1/2" Pretreated hard rock maple cutting boards for cabinets up to 27" wide with single top drawer.            These will extend out of the front of the cabinet to be flush with the drawer front.            Will not have feet attached.            We recommend that this style of cutting board be removed from the cabinet for counter top use.            A bottle of Mystery Oil for retreating the cutting board will be included.</p>	ACB-OD	
<p><b>BOTTLE OF MYSTERY OIL</b> 15oz. bottle</p> <p>For periodic re-oiling of cutting boards to preserve the beauty and durability of the natural wood surface.</p>	ABMYOIL	

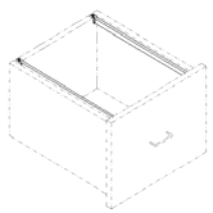
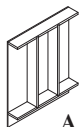
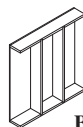
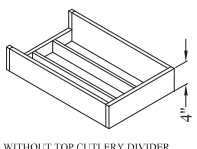
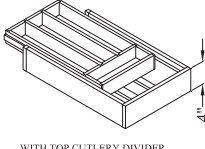
<b>BLUMOTION FULL EXTENSION UNDERMOUNT GLIDES</b>	<b>BMOT-FEUG</b>
<p>Minimum cabinet depth is 12". Minimum standard cabinet width is 12".          Shipped loose          90# per drawer capacity          NOTE: Cabinets less than 12" deep will have BLUM 7/8 extension undermount glides.          These glides give the appearance of full extension undermount glides but will not have the BluMotion mechanism.</p>	
<b>150# FULL EXTENSION SIDE-MOUNT GLIDES</b>	<b>FEG150</b>
Add to cabinet price for each drawer	
<b>HANGING FILE RAILS</b>	<b>AHANGINGFILE \$ / pair of rails</b>
<p>One pair hanging file rails installed in drawer. Front to back rails illustrated.  <b>Standard guidelines for file rail direction:</b>          Cabinets with a <i>frame opening</i> of less than 15" wide will have file rails that run side to side.          Cabinets with a 15" wide <i>frame opening</i> or greater will have file rails that run front to back.          Specify direction of file rails only if different from standard. (15" wide cabinets cannot accept front to back file rails.)          Cannot fit most standard cabinet configurations (needs a 10" deep box to accommodate, MFC will be needed on cabinet to make this change.)</p>	
	
<b>BREAD BOX LID</b>	<b>ABBL</b>
Plexi-glass sliding lid installed in drawer top	
<b>DRAWER DIVIDER</b>	<b>ADD</b>
Centered divider, dadoed into drawer box	
<b>DRAWER SPICE RACK</b>	<b>ADSR</b>
Wood spice rack drawer insert. 4 horizontal rows (in drawer box of standard 24" deep base cabinet) for storage of spice containers that are approximately 4 1/2" high.	
<b>CUTLERY DIVIDER</b>	<b>ACD (A or B)</b>
<p>Specify A, B, or C— custom. (A &amp; B have standard configurations. See illustrations)          If C is specified, send detailed drawing of divider.          Removable drawer insert with 1/2" soft maple wood partitions          2 or more dividers running front to back, evenly spaced approximately 3" apart.          NOTE: smaller width cabinets may have only one divider</p>	
 <span style="margin-left: 100px;"></span>	<b>ACD C (custom)</b>
<b>DOUBLE CUTLERY DIVIDER</b>	<b>ACD D</b>
<p>Two dividers in one drawer, priced per drawer.          Top divider (style 'A') slides back for access to lower divider (style 'B').          1/2" soft maple dividers          Front to back dividers evenly spaced, approximately 3" apart.</p>	
	
<b>PLASTIC TILT OUT SOAP TRAY</b>	<b>ATSTP</b>
Plastic soap tray attached to tilt down drawer head	
<b>TILT OUT SOAP TRAY KIT—PLASTIC</b>	<b>ATSTP KIT</b>
Hinges included. State cabinet width for correct sizing.	
<b>STAINLESS STEEL TILT OUT SOAP TRAY</b>	<b>ATSTS</b>
Stainless steel soap tray attached to tilt down drawer head	
<b>TILT OUT SOAPTRAY KIT—STAINLESS STEEL</b>	<b>ATSTS KIT</b>
Hinges included. State cabinet width for correct sizing.	

BASE ACCESSORIES

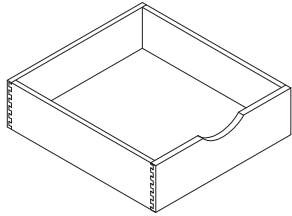
	PRODUCT CODE	LIST
<b>DELUXE UNDERMOUNT ADJUSTABLE ROLLOUT SHELVES</b>		
	2" HIGH (UP TO 24" WIDE)	ADUAROS2402
	2" HIGH (UP TO 42" WIDE)	ADUAROS2502
	4" HIGH (UP TO 24" WIDE)	ADUAROS2404
	4" HIGH (UP TO 42" WIDE)	ADUAROS2504
	6" HIGH (UP TO 24" WIDE)	ADUAROS2406
	6" HIGH (UP TO 42" WIDE)	ADUAROS2506

Adjustable natural maple rollout shelves with Blumotion full extension, undermount drawer glides on wood pilasters. If the rollout and its components need to have the specie and finish match the interior of a cabinet with a MWI modification, a quote must be submitted prior to the order being placed for correct pricing and material availability.

- Price per rollout shelf
- 100# weight capacity
- Routed handpull centered in top edge of box front.
- Dovetail construction
- Fixed center frame stile is omitted when adding a full width rollout to a cabinet 39" wide and over or a sink base.
- Not recommended for cabinets less than 15" wide. Not available for cabinets less than 9" wide or 12" deep.

\*\*Note: when using combination of rollouts and adjustable shelves in the same opening, rollouts will always be located at bottom of section unless otherwise specified.

**See below for additional guidelines.**

**Rollout Installation Guidelines**

We have classified the addition of rollouts into two different categories based on usage. First, adding rollouts to wall cabinets or an upper portion of any cabinet, will be based on the same set of rules. (Upper portion is defined as any section of any cabinet which also has a lower opening.) Then, the addition of rollouts to base cabinets and the lower portion of tall cabinets will be based on another set of rules.

1. Rollouts in wall units and upper portions of tall/base units. (Sink base cabinets will follow this same set of rules.)
  - a. When adding a **single rollout**, the rollout will be permanently mounted to the floor in that section, utilizing our Blumotion full extension under-mount glides.
  - b. Also, when adding a **single rollout**, the quantity of adjustable shelves in that section will remain the same.
  - c. When adding **more than one rollout** to a section all adjustable shelves will be deleted. When adding adjustable shelves back into the opening, each shelf will be notched to accept the ladders which are installed for the rollouts.
  - d. Also, when adding **more than one rollout** to a section our standard rollout ladder configuration will be utilized by installing the ladders full height in the interior of that section. (Full height is full usable height determined by Brighton.)
  
2. Rollouts in lower openings of base/tall units. (Except sink base cabinets.)
  - a. When adding a **single rollout** or **more than one rollout**, our standard rollout ladder configuration will be utilized by installing the ladders in the complete interior height of that section.
  - b. Also when adding a **single rollout** or **more than one rollout**, all adjustable shelves will be deleted. When adding adjustable shelves back into the opening, each shelf will be notched to accept the ladders which are installed for the rollouts.

These rules have been adopted as a standard practice for Brighton Cabinetry, Inc. Any deviation from this process must be in writing in the notes section of the order. All cabinets in our catalog with rollouts included will also follow the guidelines listed above.





# NOTES

BASE ACCESSORIES

	PRODUCT CODE	LIST
<p><b>CUTLERY DIVIDER - SILVERWARE TRAY</b></p> <p>Removable silverware tray insert with 3/8" maple partitions. Exact configuration will vary depending on interior size of drawer box. For single top drawer cabinets 18" to 30" wide. For a cabinet with two side-by-side top drawers, fits into single drawer of a 36" wide cabinet or larger.</p> <p><u>NOTE:</u> Modifications to cabinets that affect drawer size may render openings less useful or prevent the use of standard configured divider entirely. Before adding to non-standard sized cabinets, contact customer service to be sure this divider will fit. For cabinets less than 18" wide, a custom divider is required. Non-standard dividers are priced as ACD-C.</p>	ACDST	per drawer
		
<p><b>CUTLERY DIVIDER - UTILITY TRAY</b></p> <p>Removable utility tray insert with 3/8" maple partitions. Available only for 21" wide cabinet.</p> <p><u>NOTE:</u> Modifications to cabinets that affect drawer size may render openings less useful or prevent the use of standard configured divider entirely. Before adding to non-standard sized cabinets, contact customer service to be sure this divider will fit. Non-standard dividers are priced as ACD-C.</p>	ACDUT	per drawer
		
<p><b>SILVERWARE TRAY WITH KNIFE BLOCK</b></p> <p>Removable silverware tray insert with 3/8" maple partitions and maple knife block combo. Exact tray configuration will vary depending on interior size of drawer box. For single top drawer cabinets 27" to 36" wide.</p> <p><u>NOTE:</u> Modifications to cabinets that affect drawer size may render tray openings less useful. Before adding to non-standard sized cabinets, contact customer service to be sure this combo divider will fit. Custom pricing applies to non-standard dividers.</p>	ASTKB	per drawer
 <p style="font-size: small;">27" and 33" wide cabinets have 12" wide knife block (pictured) 30" and 36" wide cabinets have 6" wide knife block</p>		
<p><b>UTILITY TRAY WITH KNIFE BLOCK</b></p> <p>Removable silverware tray insert with 3/8" maple partitions and maple knife block combo. Available only for 27" wide cabinet with single top drawer. Knife block is 6" wide.</p> <p><u>NOTE:</u> Modifications to cabinets that affect drawer size may render tray openings less useful. Before adding to non-standard sized cabinets, contact customer service to be sure this combo divider will fit. Custom pricing applies to non-standard dividers.</p>	AUTKB	per drawer
		
<p><b>KNIFE BLOCK</b></p> <p>Block made of maple and will fit in top drawer of B15 and smaller. Or if the cabinet has two side-by-side top drawers, fits a single drawer of a 30" wide cabinet or smaller.</p> <p><u>Note:</u> If a larger knife block is wanted, contact Customer Service for pricing.</p>	AKB	
	 <p style="font-size: x-small;">Close-up view with knives</p>	

BASE ACCESSORIES

PRODUCT LIST  
CODE CODE

**TOE KICK STEP STOOL**

TKSS

Minimum width of cabinet to install Toe Kick Step Stool is 18".

Added to cabinet price.

Recessed side toe and / or rear toe modifications may not allow enough space for this item.

**TOE KICK DRAWER - 24" DEEP**

ATKD1824

Add to 24" deep cabinets.

Operational, 2" high drawer box added into toe kick space.

3/4" thick solid wood face frame at bottom and sides.

Toe notch for side of cabinet remains the same height and depth as standard after the 1/4" AMTK has been applied to adjacent cabinets.

Actual front to back depth of drawer box is 18" for 24" deep unit.

Drawer fronts are slab; 5 pc. not available.

Minimum overall cabinet depth is 18" due to limited access to the drawer box under the cabinet.

Illustration depicts B3D cabinet with ATKD accessory installed.

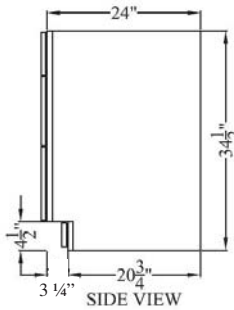

ATKD2124

ATKD2424

ATKD2724

ATKD3024

ATKD3324

ATKD3624

**TOE KICK DRAWER - 21" DEEP**

ATKD1821

Add to 21" deep cabinets.

Operational, 2" high drawer box added into toe kick space.

3/4" thick solid wood face frame at bottom and sides.

Toe notch for side of cabinet remains the same height and depth as standard after the 1/4" AMTK has been applied to adjacent cabinets.

Actual front to back depth of drawer box is 15" for 21" deep unit.

Drawer fronts are slab; 5 pc. not available.

Minimum overall cabinet depth is 18" due to limited access to the drawer box under the cabinet.

Illustration depicts B3D cabinet with ATKD accessory installed.

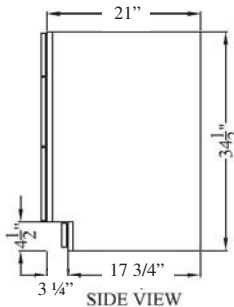

ATKD2121

ATKD2421

ATKD2721

ATKD3021

ATKD3321

ATKD3621

**TOE KICK DRAWER - 18" DEEP**

ATKD1818

Add to 18" deep cabinets.

Operational, 2" high drawer box added into toe kick space.

3/4" thick solid wood face frame at bottom and sides.

Toe notch for side of cabinet remains the same height and depth as standard after the 1/4" AMTK has been applied to adjacent cabinets.

Actual front to back depth of drawer box is 12" for 18" deep unit.

Drawer fronts are slab; 5 pc. not available.

Minimum overall cabinet depth is 18" due to limited access to the drawer box under the cabinet.

Illustration depicts B3D cabinet with ATKD accessory installed.

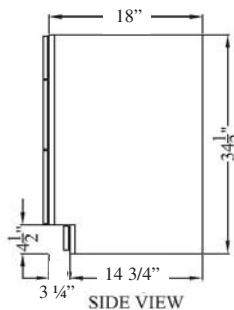

ATKD2118

ATKD2418

ATKD2718

ATKD3018

ATKD3318

ATKD3618

**BASE ACCESSORIES**

**PRODUCT CODE      LIST**

**POT AND PAN CADDY**

**ABPPC**

20" width, 14 1/2" height, 22 1/8" depth  
 Birch veneer, wood platforms with heavy duty chrome-plated wire surrounds for storage of cook ware and lids.  
 Two shelves pull out individually using full extension ball-bearing slides.  
 Upper shelf has two side racks.  
 Maximum weight capacity of 25lb. per shelf  
 Will fit minimum of 24" wide, 24" deep cabinets. (Inset cabinet doors must be able to open fully.)  
 Inset Concealed has to be a 27" wide cabinet.



**HAMPER BASKET ROLLOUT**

**AROHB**

Add to cabinet price  
 Epoxy coated steel wire basket on glides, mounted to bottom of cabinet.

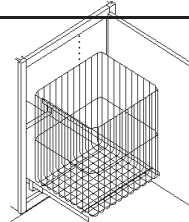

**VEGETABLE BIN**

**AVGB**

3 shallow wire baskets  
 Standard sizes to fit 15" wide and 18" wide base units



**LIFT UP MIXER SHELF**

**ALUMS**

3/4" plywood shelf installed on lift up mechanism.  
 Width of shelf equals face frame opening width minus 3".  
 When added to a cabinet, this accessory item omits the adjustable shelves from that cabinet.  
 The recommended cabinet width is 18".  
 Minimum frame opening height is 23 1/4" (will not fit in standard base cabinet with a top drawer.)  
 Minimum cabinet depth is 24" (shelf depth equals 20 1/2").

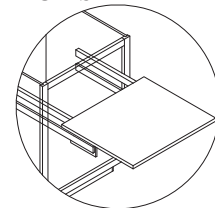

**METAL TOWEL RACK**

**ATR**

Pullout metal towel rack mounted inside cabinet. Specify installation location.  
 6" wide minimum opening necessary.  
 Not recommended for use on BDS or BRCS due to sink clearance.

**BASE TRAY DIVIDER**

**ABTD**

1/2" UV Birch veneer plywood divider.  
 Specify location and spacing of multiple dividers.  
 Tray dividers will be equally spaced in the opening unless otherwise specified.  
 Adjustable shelves cannot be adjacent to tray dividers. A partition must be used if adjustable shelves are needed.

**BASE PARTITION**

**ABP**

3/4" UV Birch veneer plywood, centered unless otherwise specified. When specified for cabinets with shelves, shelves are installed on both sides. Use when adding an accessory on one side of cabinet, shelves are installed on opposite side. Specify location of partition and side of accessory installation if required.

**BASE END SKIN**

**ABSKIN**

1/4" panel matching specie and finish of order

**SQ FT**



<b>BASE ACCESSORIES</b>
-------------------------

<b>PRODUCT CODE</b>	<b>LIST</b>
-------------------------	-------------

---

<b>BASE WOOD REVOLVING SHELF</b>	<b>ABWRS</b>
----------------------------------	--------------

Revolving platter added to shelf for diagonal corner or pie cut base cabinet.

---

<b>BASE WOOD REVOLVING SHELF-6" DEEP</b>	<b>ABWRS-6</b>
--	----------------

Deep revolving platter added to shelf for pie cut cabinet only. Platter has 6" high lip and is approximately 30" diameter. Not available for units smaller than 36" wide in either direction.

---

<b>SINK BASE DRIP TRAY-INSTALLED ONLY</b>	<b>ASBDT</b>
---	--------------

Almond colored, under sink drip tray for installation in NEW 36" wide x 24" deep base cabinet. Width can be cut down to fit in 33" wide x 24" deep NEW cabinet, also.

Cannot be installed around existing plumbing.

Cannot be installed in post notch or clip corner style cabinets.

Resistant to most household chemicals. Wipes clean.

Unique design funnels excessive water to the front of the cabinet and onto the floor as an alert to a leak.

Tray measures 11/16" high and holds up to 1.75 quarts of water.

---



## BASE MODIFICATIONS

	PRODUCT CODE	LIST
<b>FRAME CHANGE</b>	MFC	
Includes one or all changes made to frame configuration, excluding extended stiles and rails. Specify changes and dimensions, provide sketch.		
<b>INCREASE CASE DIMENSION MODIFICATION</b>	MICDIM	
Used to increase height, and/or width, and/or depth above the largest standard sizes. Cabinet may be increased up to 3" larger for any or all dimensions. Dimension increases beyond 3" require a quote. Some restrictions apply due to material availability. Any cabinet increased in width to 39" or above will have a fixed center stile as standard. Drawer boxes and rollouts will increase with the cabinet depth up to 27" deep cabinets. Anything increasing over 27" in depth must be verified with Customer Service for availability before ordering. Wall cabinets and sink cabinets can be increased in <u>depth only</u> up to a maximum of 3" beyond the standard cabinet depth for no up charge at all.		
<b>MATCHING WOOD INTERIOR</b>	MMWI	
Wood specie and finish match frame and doors. Price % of list price. When selecting matching wood interior on cabinets with more than one section (ie, tall cabinets or combined cabinets) the entire interior of all sections will be matching wood interior as standard. The grain on interior backs <u>may be</u> horizontal on cabinets larger than 48" wide.		
<b>COMBINE CABINET CHARGE</b>	COMBINE	
Used to combine two or more cabinets. One charge per combination of two cabinets.		
<b>BASE FRONT ONLY</b>	MBFRO	
Subtract from base price of cabinet. Doors are hinged and working. Specify if fixed doors are required. Floor not included. Unless specified, front will be shipped without sub-toe kick. Overall frame height will be 4 1/2" less product height ordered unless MFTK (flush toe) is added. Example: BFD21R (std. 34 1/2" high) + MBFRO ordered, shipped frame height = 30".		
<b>OMIT DOORS</b>	MOD	
Interior remains standard finish unless matching wood interior modification is used.		
<b>ADD CENTER STILE</b>	MACSB	
To add vertical center stile to any cabinet. Standard 1 1/2" wide stile, specify width of stile if different dimension is desired.		
<b>ADD CENTER RAIL</b>	MACRB	
To add a horizontal center rail and fixed floor to any cabinet. Standard 1 1/2" wide rail, specify width of rail if different dimension is desired. Include specific information for placement of rail, provide drawing if possible. Charge includes cost for dividing doors into separate uppers and lowers.		
<b>APPLIED MOLDING CHARGE</b>	MAMC	\$ EA
Charge to apply molding, ornaments, appliqué to cabinets.		

BASE MODIFICATIONS

	PRODUCT CODE	SPECIFY	LIST
<b>Furniture Ends– <i>Locking Miter Joint</i></b>			
<ul style="list-style-type: none"> <li>• True flush ends with no seams, making crown, base, and light rail moldings easier to attach, no scribe molding needed</li> <li>• Not available on diagonal corner cabinets, angled cabinets, clipped corners, or radius cabinets.</li> </ul>			
<b>Base Furniture Finished End (Left, Right, or Both ends)</b>	MBFURNFE	L/R	SQFT
<b>Base Furniture False Door Ends (Left, Right, or Both ends)</b>	MBFURNFD	L/R	\$ / SQFT
<b>Base Furniture Wainscot End (Left, Right, Both ends)</b>	MBFURNWP	L/R	\$ / SQFT
<ul style="list-style-type: none"> <li>• Not available with any miter doors, Also not available with Churchill, Madrid, Plainfield, Plainfield MDF, Sardinia, Valletta, or Verona door designs</li> </ul>			





BASE MODIFICATIONS

	PRODUCT CODE	SPECIFY	LIST
<b>BASE FINISHED END</b> Side of cabinet matches specie and stain of front frame and doors. Side retains 1/4" scribe reveal same as unfinished side.	MBFE	L / R	SQ FT
<b>BASE FLUSH FINISHED END</b> A 1/4" panel is applied creating a flush end. Side of cabinet matches specie and stain of front frame and doors.	MBFFE	L / R	SQ FT
<b>FINISHED BACKS 1/2"</b> Back thickness does not affect overall depth of cabinet. Vertical grain is standard.	MFBAH		SQ FT
<b>BASE FALSE DOOR ON END</b> Includes flush finished end.	MBFDE	L / R	SQ FT
<b>BASE WAINSCOT END PANEL</b> A 3/4" panel constructed from same material as cabinet doors, applied flush with cabinet end. Center panel will be divided to best align with doors on face of cabinet. Bottom rail will be wider for toe space unless cabinet ships with a side toe or loose toe. <b>Not available for mitered door styles.</b>	MBWEP	L / R	SQ FT
<b>BASE BEAD BOARD END</b> 1/2" solid wood, tongue and groove bead board, factory installed on cabinet side.	MBBDE	L / R	SQ FT
<b>BEAD BOARD INTERIOR BACK</b> 1/2" solid wood, tongue and groove bead board installed in the back of cabinet.	MBDIB		SQ FT
<b>BASE GROOVED PANEL LEFT / RIGHT</b> 1/4" veneered panel with MDF core applied, creating a flush end. 1/8" wide, vertical 'V' grooves, spaced 1 1/2" apart. Other designs to match grooved doors are available upon request. Matches specie and stain of front frame and doors. <b>Not available for any finish with wear sanding.</b> Not available in Rustic Alder or Rustic Hickory: standard grade wood will be substituted.	MBGP	L / R	SQ FT
<b>BASE GROOVED PANEL INTERIOR BACK</b> 1/4" veneered panel with MDF core installed in the back of the cabinet. 1/8" wide, vertical 'V' grooves, spaced 1 1/2" apart. Other designs to match grooved doors available upon request. Matches specie and stain of front frame and doors. Use with MWI modification to finish the remainder of cabinet interior. <b>Not available for any finish with wear sanding.</b> Not available in Rustic Alder or Rustic Hickory: standard grade wood will be substituted.	MBGPIB		SQ FT
<b>BASE GROOVED PANEL BACK (1/2")</b> 1/2" veneered panel with MDF core applied to the case back. 1/8" wide, vertical 'V' grooves, spaced 1 1/2" apart. Other designs to match grooved doors are available upon request. Matches specie and stain of front frame and doors. Back thickness does not affect overall depth of cabinet. <b>Not available for any finish with wear sanding.</b> Not available in Rustic Alder or Rustic Hickory: standard grade wood will be substituted.	MBGPBAH		SQ FT
<b>BASE FINISHED TOP</b> Finished top added, matching specie and finish of cabinet. Installed with recess from top edge of frame rail similar to wall cabinet construction. Finished ASCRIBE-2 covers the exposed case sides and back. Edgebanding for the side edges and back top edge is an add-on option. This must be noted on order and appropriate EB charges apply.	MBFT		
<b>BASE FLUSH FINISHED TOP</b> Flush panel matches specie and finish of cabinet. To cover exposed side edges of flush finished top, flush finished ends must be ordered.	MPFFT		SQ FT



**BASE MODIFICATIONS**

	PRODUCT CODE	SPECIFY	LIST
<b>BASE EXTENDED STILE OUT... UP TO 3"</b> (see next page for illustrations) Stile extends outward from cabinet, increasing overall frame width by the amount specified for the extension. Overlay filler strips are available for full-overlay flush look. (See base cabinet accessories)	MBESO3	L / R	
<b>BASE EXTENDED STILE OUT...UP TO 6"</b> (see next page for illustrations) Stile extends outward from cabinet, increasing overall frame width by the amount specified for the extension. Overlay filler strips are available for full-overlay flush look. (See base cabinet accessories)	MBESO6	L / R	
<b>BASE EXTENDED STILE IN...UP TO 3"</b> (see next page for illustrations) Stile extends inward, overall frame width does not change. Overlay filler strips are available for full-overlay flush look. (See base cabinet accessories)	MBESI3	L / R	
<b>BASE EXTENDED STILE IN...UP TO 6"</b> (see next page for illustrations) Stile extends inward, overall frame width does not change. Overlay filler strips are available for full-overlay flush look. (See base cabinet accessories)	MBESI6	L / R	
<b>BASE EXTENDED STILE DOWN</b> Extends stile (specify left or right) down into the toe kick space to meet the floor.	MBESD	L / R	
<b>EXTEND TOP OR BOTTOM RAIL UP</b> (see next page for illustrations) Add to cabinet price. Indicate overall dimension.	METRU MEBRU		
<b>EXTEND TOP RAIL DOWN</b> (see next page for illustrations) Add to cabinet price. Indicate overall dimension.	METRD		
<b>VALANCE TOP RAIL</b> Extends a standard 1 1/2" wide top rail down for an overall rail width of 5". Price for cabinets up to 42" wide. Specify shape: Classic Arch, Elegant Arch, Straight, Arched, Furniture, Shaker style A or Shaker style C. Provide a sketch or template for custom pattern, requires quote.	MVTR		
<b>VALANCE BOTTOM RAIL</b> Price for cabinets up to 42" wide. Specify shape: Classic Arch, Elegant Arch, Arched, Furniture, Shaker style A or Shaker style C. Use MFTK, flush toe kick modification, when the Straight valance design is wanted. Provide a sketch or template for custom pattern, typically requires a quote. Base and tall cabinets with this bottom rail modification will still have the subtoe behind the valance bottom rail. The subtoe ships finished and will <u>not</u> require a separate AMTK.	MVBR		
<b>BASE EXTEND SIDE BACK</b> Specify the length of the extension beyond the standard depth. 48" overall maximum depth. Back edge will not be finished as standard. Please specify on order for finished edge and add appropriate EB charges.	MBESB	L / R	\$ /ea.6'
<b>BASE RECESSED SIDE</b> Normally used when a recess allowance is needed for a field applied panel. The cabinet face frame and door reveals will not change with this modification. Most standard cabinets already have 1/4" recess behind the face frame, specify <u>TOTAL</u> amount needed. Maximum overall recess allowed = 7/8".	MBRS	L/R	

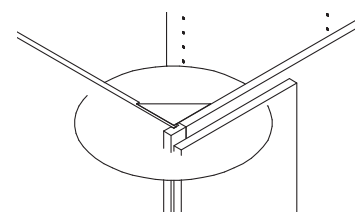

# EXTENDED RAIL AND STILE ILLUSTRATIONS

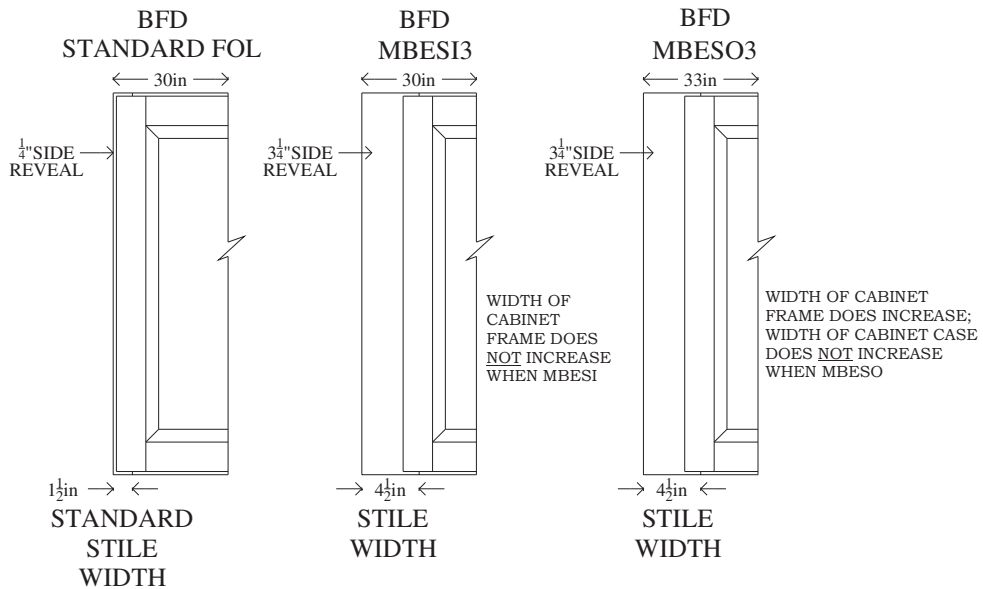
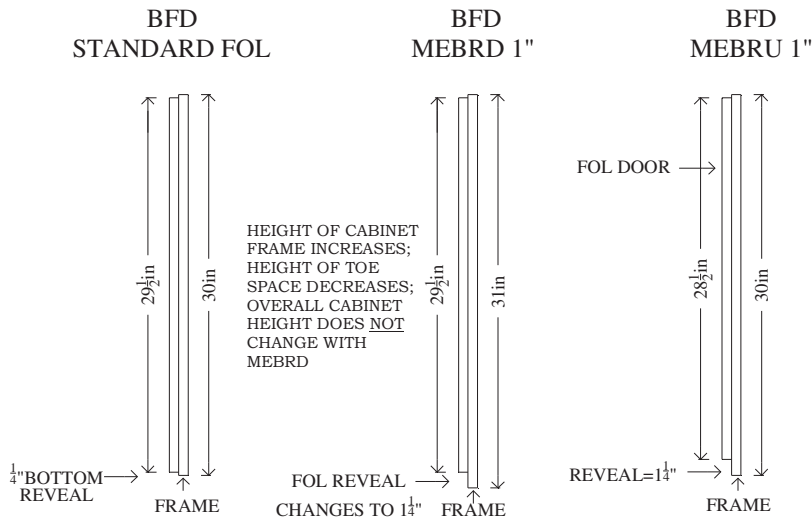
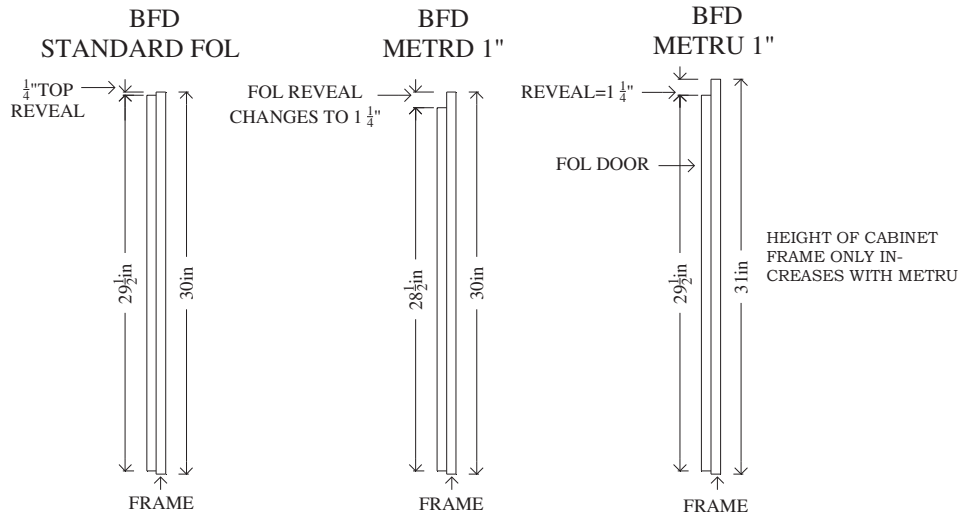



**BASE MODIFICATIONS**

	PRODUCT CODE	SPECIFY	LIST
<b>BASE SIDE ANGLED</b>	MBSA	L / R	
<p>Side is angled, front frame is parallel to back.            Include a top view sketch with dimensions of side and front. Specify a degree of angle.            Use widest dimension of finished cabinet as initial starting price then add modification charge.</p>			
<b>BASE ANGLED SIDE ENTRY</b>	MBAE	L / R	
<p>This modification is like base side angled but with frame and working door.            Include a top view sketch with dimensions of side and front.            Specify degree of angle and hinging.            Use widest dimension of finished cabinet as initial starting price then add modification charge.</p>			
<b>BASE ANGLED FRONT</b>	MBAF	L / R	
<p>Front is angled, sides remain perpendicular to back.            Include a top view sketch with dimensions of sides and front.            Specify overall cabinet size. Indicate depth of right and left sides.            Minimum depth is 4" for adjustable shelves.            Use widest dimension of finished cabinet as initial starting price then add modification charge.</p>			
<b>BASE END ENTRY</b>	MBEE	L / R	
<p>Specify door hinging.            Add modification charge to initial starting price of cabinet.</p>			
<b>DOUBLE ENTRY</b>	MDE		
<p>Add modification charge to initial starting price of cabinet.            Specify hinging on rear if different from front entry.</p>			
<b>BLIND BASE CUSTOM FRONT</b>	MBBCF		
<p>Use to make special size front and blind area            Provide sketch of front opening and blind area dimensions            Example; to create a blind cabinet with an overall width size of 45" with a 30" front (27" opening) and a 15" blind area, price as a regular B30 and add \$.</p>			
<b>BASE FINISHED BLIND SOLID</b>	MBFBS		
<p>3/4" wood fill-in of entire blind area in matching wood and finish</p>			
<b>FLUSH TOE KICK</b>	MFTK		
<p>Per cabinet front            Note: When adding this to base or tall cabinets and also requesting that the flush toe is cut into a valance shape, there will be a subtoe behind the valance bottom rail. The subtoe piece ships finished and does <u>not</u> require a separate AMTK.</p>			
<b>LOOSE TOE KICK</b>	MLSTK		
<p>Shipped loose. Overall shipped cabinet height is reduced 4 1/2".</p>			
<b>OMIT TOE KICK</b>	NOTK		
<p>Removes the toe kick area from the cabinet. Overall shipped cabinet height is reduced 4 1/2".</p>			
<b>SIDE TOE KICK</b>	MLTK	(Left)	
<p>Add to cabinet price            Specify left or right or left and right</p>	MRTK	(Right)	
	MLRTK	(Left/Right)	
	MBTK	(Back)	
<b>BACK TOE KICK</b>	MBTK	(Back)	
<p>Add to cabinet price            Specify back or combination of back and side(s)</p>	MBLTK	(Back/Left)	
	MBRTK	(Back/Right)	
	MBLRTK	(Back/Left/Right)	

**BASE MODIFICATIONS**

PRODUCT SPECIFY LIST  
CODE

**UNIVERSAL ACCESS TOE KICK SPACE**

MUATOE

Modifies the cabinet's toe kick to 9" high x 6" deep as recommended by the Americans with Disabilities Act 2010 standards. Specify if other dimensions are needed.

Note: Using this modification can affect other aspects of the cabinetry and may cause some configurations to no longer be available. Examples of this include, but are not limited to, a B4D and a BM2DF.

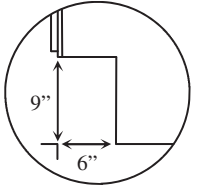

**BASE DUCT CUTOUT**

MBDCO

Include a top view sketch with cutout dimensions and location.

**SINK SIDE CUTOUT**

MSSCO

6" high cutout at top edge of both sides. Starts and ends 2" from front and back edges.

**BASE CLIPPED CORNER**

MBCC

L / R

Stile is angled at 45 degrees. The face frame is decreased by 3" per clipped corner. This modification does not increase the width or depth of the cabinet.

Per side

**RECESS POST CUTOUT**

MRPC

L / R

Post not included, accepts up to a 6" post. Specify size of cutout: width x depth. Cutout space will be 3/4" finished frame stock

Per side

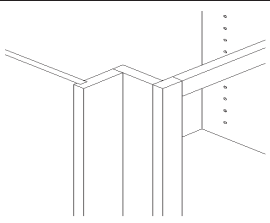

**BASE FLUTING**

MBFLUTE

Routed on filler or stile up to 6" wide. Three flutes are standard, based on 3" filler. Specify the number of flutes if different (1 flute per inch is recommended). Limits will normally align with adjacent cabinets. Standard is 3/8" flute with 3/8" space between flutes. Provide sketch on special fluting requirements. Minimum filler width is 1 1/2".

**ROSETTE DESIGN**

MROSETTE

Routed into filler, usually accompanies fluting. Style A (2 1/4") is for 3" filler or overlay filler (2 3/4") with machine or L149 edge. Minimum overlay filler width will be 3 1/8" for all other edge profiles. Style B (3 1/8") is for 6" filler.

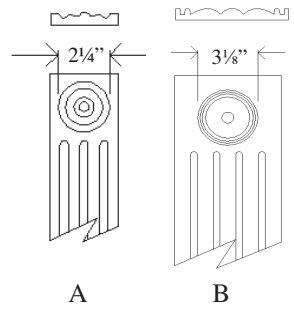

BASE MODIFICATIONS

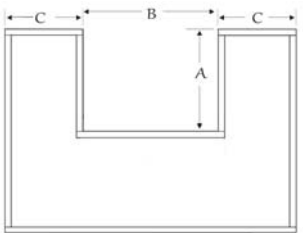
	PRODUCT CODE	LIST
<p><b>FLIP DOWN DOOR STAY</b></p> <p>Supports a door hinged to the bottom of a cabinet opening            Priced per piece (2 doors maximum)            Will not fit frame opening less than 7" high</p>		MFDDS \$ / CAB (2 doors max.)
<p><b>90 DEGREE HINGING (concealed hinge only)</b></p> <p>Hinge with restricted swing of approximately 90 degrees.            Available for <u>concealed</u> hinges only.            Priced per cabinet side            Specify side: L or R</p>	MB90DEG-L MB90DEG-R	
<p><b>BASE ADDITIONAL DRAWER, STANDARD</b></p> <p>Use this modification to add a drawer that would require a frame opening of 6" H or less.            Blumotion glides standard: other glide styles will be substituted when the frame opening for the drawer boxes are under 6" wide or cabinet is less than 12" deep.            This price includes drawer box, hardware, drawer front, and frame change.</p>	MBADS Specify: SLAB 1INSLAB 5-PIECE	INSET SOL FOL
<p><b>BASE ADDITIONAL DRAWER, DEEP</b></p> <p>Use this modification to add a drawer that would require a frame opening greater than 6" high.            Blumotion glides standard: other glide styles will be substituted when the frame opening for the drawer boxes are under 6" wide or cabinet is less than 12" deep.            This price includes drawer box, hardware, drawer front, and frame change.</p>	MBADD Specify: SLAB 1INSLAB 5-PIECE	
<p><b>5-PIECE DRAWER HEAD UPGRADE</b></p> <p>Price per drawer head.            The top and bottom rails of the drawer head are cut down for most designs.</p>	5-P(RAIS)-FOL 5-P(FLAT)-FOL 5-P(RAIS)-SOL/INSET 5-P(FLAT)-SOL/INSET	
<p><b>1" THICK, SLAB DRAWER FRONT UPGRADE</b></p> <p>Price per drawer head.            Not available to match all designs. Not recommended with slab doors or designs with flat center panels. See Introduction for more information.</p>	1-INSLAB-FOL 1-INSLAB-SOL/INSET	
<p><b>DRY SEED SEE THROUGH DRAWER FRONT</b></p> <p>Wood frame and a plexi-glass center panel with divider positioned behind the clear panel.</p>	MDSDF	per drawer
<p><b>SCOOPED DRAWER SIDES</b></p> <p>Standard scoop is 2" down from top edge and begins 1-1/4" back from front edge unless otherwise specified.            Minimum drawer box height is 4".</p>	MSDS	
<p><b>OMIT OPERATING DRAWER BOX</b></p> <p>Omits the operating drawer box and hardware from a standard cabinet. The drawer front will be attached to the cabinet as a false front. If the cabinet has more than one drawer top-to-bottom, this modification will remove the top drawer box unless otherwise specified. If the cabinet has multiple drawers side-to-side, you must specifically note on the order which box is to be removed, such as 'omit left drawer box'.</p>	MOODB	per drawer
<p><b>U-SHAPE DRAWER BOX MODIFICATION</b></p> <p>Modifies an existing drawer box to have a cutout centered, side to side, allowing space for pipe work. <u>Drawer box</u> width must be at least 12" (12 3/8" frame opening). Must specify dimensions 'A' and 'B' as shown on the template. 'C' can be no less than 3".</p>	MUDRBOX 	per drawer



# NOTES